



BOROUGH OF WATCHUNG

15 MOUNTAIN BOULEVARD
WATCHUNG, NEW JERSEY 07069

MAYOR & COUNCIL MEETING AGENDA

THURSDAY, AUGUST 15, 2024

7:30 P.M.

MAYOR

Ronald Jubin, Ph.D.

COUNCIL

Christine B. Ead, President

Curt S. Dahl

Paul Fischer

Paolo Marano

Sonia Abi-Habib

Robert Gibbs

James J. Damato
Business Administrator

Edith G. Gil
Borough Clerk

Joseph Sordillo, Esq.
Borough Attorney

THIS MEETING AND ALL BUSINESS SHALL BE CONDUCTED IN-PERSON, INCLUDING THE ACCEPTANCE OF PUBLIC COMMENT. No public comment shall be allowed to be made virtually or accepted in writing and read into the record. All writings received shall be acknowledged and accepted by the Council as regular correspondence. The Borough may broadcast its meetings virtually for public viewing as a courtesy.

VIEWING INSTRUCTIONS: To listen to the meeting via phone, dial 1 (646) 558-8656. It will prompt you for a meeting ID. Type **99501390087#**. You do not need a participating ID, just press # | To view the meeting using a smart phone or computer, download the free **ZOOM** app. Type in the **meeting ID 99501390087** or click on <https://zoom.us/j/99501390087>. **Agenda items can also be requested by emailing egil@watchungnj.gov**

**BOROUGH OF WATCHUNG
MAYOR & COUNCIL MEETING AGENDA**

AUGUST 15, 2024 - 7:30 P.M.

MAYOR’S STATEMENT: This meeting is being held in compliance with the Open Public Meetings Act. Under the provisions of N.J.S.A.10:4-6 et seq., notice of the time and place of this meeting was given by way of the Annual Meeting Notice to the Courier News, Echoes Sentinel, the Star Ledger, posted at Borough Hall and on the Borough’s website.

**SALUTE TO THE FLAG and MOMENT OF SILENCE FOR OUR SERVICE MEN AND WOMEN,
SERVING HOME AND ABROAD**

ROLL CALL

PROCLAMATION

- ❖ Spinal Muscular Atrophy (SMA) Awareness

SPECIAL PRESENTATION

- ❖ Bruno Associates, Grant Consultants

REPORTS OF STANDING COMMITTEES

1. Administration & Finance
2. Police
3. Public Works / Buildings and Grounds
4. Public Affairs:
 - Environmental
 - Recreation
 - Historical
 - Board of Health
 - Green Team
5. Fire
6. Laws/Ordinances

REPORTS OF BOROUGH OFFICERS

7. Engineer
8. Police Chief
9. Fire Official
10. Emergency Management
11. Rescue Squad
12. Attorney
13. Finance
14. Clerk
15. Administrator
16. Planning Board
17. Municipal Alliance
18. Library Advisory Committee
19. Traffic and Beautification

**BOROUGH OF WATCHUNG
MAYOR & COUNCIL MEETING AGENDA**

AUGUST 15, 2024 - 7:30 P.M.

PUBLIC PORTION / AGENDA ITEMS ONLY

*A public portion is held prior to Council action **for comments of agenda items only**. Individuals commenting are limited to **3 minutes** per person, and will not be permitted to speak again until everyone has had an opportunity to speak. If a group is represented by an attorney, the attorney will be given 5 minutes to make the presentation for the group.*

DISCUSSIONS

- ❖ Fitness Equipment & Park Facilities

OLD BUSINESS

ORDINANCE ON SECOND READING / PUBLIC HEARING

OR#24/13: AMENDING THE BOROUGH’S CODE, CHAPTER 11, GENERAL LICENSING, TO ESTABLISH BUSINESS REGISTRATION INSURANCE REQUIREMENTS IN COMPLIANCE WITH STATE LAW

NEW BUSINESS

REPORTS & CORRESPONDENCE:

Acknowledging Receipt of the following Borough Reports:

Animal Control Solutions Monthly Report	July 2024
Board of Adjustment Meeting Minutes	July 11, 2024
Construction Monthly Report	July 2024
Fire Prevention Monthly Report	July 2024
Green Team Meeting Minutes	June 26, 2024
Historical Committee Meeting Minutes	June 19, 2024
Planning Board Meeting Minutes	May 21, 2024

#14: Request to Place Teal Ribbons (Ovarian Cancer Awareness) around Watchung Lake/Borough Hall in September, recv’d 7/22/24, cc: M&C, JD

#15: Public Notice of Planning Board Hearing on August 20th, Applicant Bonnie Burn Redevelopers Urban Renewal, LLC, recv’d 8/2/24, cc: M&C, JD

CONSENT ITEMS

The resolutions listed below were submitted to the Governing Body for review and will be adopted by one motion.

R1: Authorizing Purchases Over Allowed Threshold – BL Contracting (*Library Asbestos Abatement*)
Winner Ford (*2025 Ford Interceptor SUV (2)*)
Axon Enterprise (*PD redaction, respond+ software, year 2*)

R2: Authorizing Refund for Tax Overpayment of 40 Reynolds Drive

R3: Authorizing Bill List

**BOROUGH OF WATCHUNG
MAYOR & COUNCIL MEETING AGENDA**

AUGUST 15, 2024 - 7:30 P.M.

R4: Authorizing a Refund to Asha Ricci for Summer Camp Fees

R5: Consenting to the Proposed Northeast, Upper Raritan and Lower Raritan/Middlesex County Water Quality Management Plan Amendment

R6: Waiving Chapter 6-2.11 of the Borough Code for Movie Night Event on September 13th

NON-CONSENT ITEMS

R7: Amending a Revocable License Agreement for 23 Blue Wolf Trail, Block 43.04/Lot 17.11

R8: Authorizing Change Order for MTM Metro Corp for the Removal & Disposal of Asbestos Containing Materials at Watchung Library

R9: Authorizing Temporary Construction License for 636 Valley Road, Block 6905/ Lot 13

R10: Authorizing Temporary Construction License for 10 Frair Lane, Block

INTRODUCTION OF ORDINANCE

OR #24/14: ORDINANCE REVISING CHAPTER 2, ADMINISTRATION, OF THE CODE OF THE BOROUGH OF WATCHUNG TO ESTABLISH THE WATCHUNG YOUTH SERVICES COMMISSION

PUBLIC PORTION - GENERAL DISCUSSION

Individuals commenting are limited to 3 minutes per person. An Attorney will be given 5 minutes to present on behalf of a group.

EXECUTIVE SESSION

R11: Authorizing Executive Session to Discuss Contract Negotiations and Anticipated Litigation

The Borough Council may take official action on those items discussed in executive session upon return to open session

ADJOURNMENT

The next meeting of the Mayor and Council will be Thursday, September 5, 2024 at 7:30 P.M.

BOROUGH OF WATCHUNG

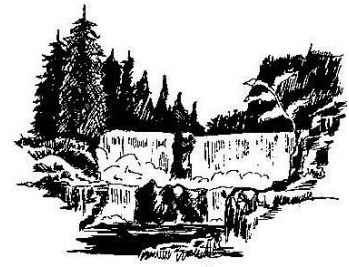

Public Works Committee

Chair: Ead

Abi-Habib

Dahl

The Committee met with the Administrator, Borough Engineer, and Public Works Foreman on August 8, 2024 to discuss the following:

- 1) **PSE&G Updates (all noted online for changes)**
 - 8/12 – 8/23 2024
 - (roads with construction in progress or complete)
 - 8/12-8/23 Night Work, Hilcrest, Crestwood, Valley Road
 - 8/12-8/23 Day Work, Valley Drive, Johnson Dr., Valley
 - 8/20-8/23 Day Work, Brook, Valley Dr.
 - 8/12-916 Day Work, Stirling, Brookdale, Natalie's Way
- 2) **2024 DOT Grant Road Project Award: \$337,210**
 - Updated quote: \$502,287-
 - scheduled to start and complete by end of August
 - Vail Lane, Wolford Court, and Drift Road
- 3) **2025 DOT Road Project: (Submit by July 1, 2024)**
Brookdale, Anderson Rd., and Skyline Dr.
- 4) **Working on plan for Endeavor Grant received: \$66,000-**
- 5) **New Gaga Court Equipment Completed at Mobus Field**
- 6) **Gazebos on Village Green and Mountain Blvd**
 - repaired, new roof, paint stained, and new lighting
- 7) **Library Bridge:**
 - In final stages of completion, Rails planned for installation
- 8) **Phillips Bridge**-Engineering plan in works for use of FEMA funds to sure up Abutment/Stabilization
- 9) **Library:**
 - Internal demolition and clean out to begin late August
- 10) **Sidewalk/Valley Furniture across parking lot to Best Lake**
 - Working on Bid, plans to begin work as soon as possible

BOROUGH OF WATCHUNG



- 11) **Phase Two Sidewalk Project**
-Working with County for next steps and plan to continue 2025 budget
- 12) **Review walk-path Brookdale/Parking Lot Projects**
- 13) **Watchung Lake and Best Lake Dredge/other**
-Constant review of Grant Options and critical funding
- 14) **I & I Study/repairs in review using grant funds**
- 15) **Ness Farm:**
-Moving forward with grant opportunity to review clean-up/cap
Opportunity options
- 16) **NJ DEP MS4 Permit Requirements:**
(Proposal on track)
-\$15,000 received. 2nd grant submitted,
-\$15,000 each year for 2-years Borough investment
- 17) **Gazebo Mountain Blvd and Village Green**
-Power wash completed, stain work in progress w/o 6-24
(Sherwin Williams Charwood SW 3542SS, Contractor TBD)
-Fundraising from T&B will go toward solar lighting option for Mt. Blvd
- 18) **Continued Tree Planting/Replacement:**
Somerset St., other areas throughout Borough (some completed, others
Slated for Fall 2024
- 19) **Street Sweeping (Ordered), some roads complete, others on the list**
- 20) **Cement work:**
-New steps at Texier Complete, railings to follow
- 21) **Blackadar sign for Phillips Field** (in work as well as The New
“God’s Acre Sign”
- 22) **Culvert Inspection:** Leaves and debris on regular basis
- 23) **DPW to work on Police Station repairs to gym area**

**BOROUGH OF WATCHUNG
ORDINANCE NO. 24/13**

***AMENDING THE BOROUGH'S CODE, CHAPTER 11, GENERAL
LICENSING, TO ESTABLISH BUSINESS REGISTRATION INSURANCE
REQUIREMENTS IN COMPLIANCE WITH STATE LAW***

WHEREAS, the New Jersey Legislature enacted P.L. 2022, c.92 (N.J.S.A. 40A:10A-1 and -2), establishing new liability insurance registration requirements for business owners and owners of rental units in each municipality; and

WHEREAS, P.L. 2022, c.92, requires all municipalities to require business owners and owners of rental units to register with each municipality the filing of evidence of insurance as required by the State law; and

WHEREAS, the Borough of Watchung desires to comply with P.L. 2022, c.92 through the adoption of this Ordinance.

NOW, THEREFORE, BE IT ORDAINED by the Mayor and Borough Council of the Borough of Watchung, in the County of Somerset and State of New Jersey as follows:

Section 1. Chapter 11 entitled "General Licensing" of The Code of the Borough of Watchung is hereby supplemented and amended to establish and codify new Section 11-11 to be entitled "Business Registration" to read as follows:

Chapter 11. General Licensing.

§11-11. Business Registration

§11-11.1 Purpose; Established.

The purpose of this Section is for the Borough's compliance with the municipal registration requirements established in New Jersey P.L. 2022, c.92 (N.J.S.A. 40A:10A-1 and -2), as may be amended.

§11-11.2 Registration Required.

- A. The owner of a business, the owner of a rental unit or units, and the owner of a multi-family home of four or fewer units, one of which is owner-occupied, shall annually register with the Borough Fire Official, which registration shall include the certificate of insurance

**BOROUGH OF WATCHUNG
ORDINANCE NO. 24/13**

**2nd Reading
Public Hearing**

demonstrating compliance with this Chapter and N.J.S.A. 40A:10A-1 (P.L. 2022, c.92), as may be amended.

- B. The annual registration shall include an annual fee of \$25.00 per business, rental unit(s), and multi-family home subject to this Chapter.

§11-11.3 Insurance Requirements.

- A. Except as provided in Section 11-11.3(B), the owner of a business or owner of a rental unit or units shall maintain liability insurance for negligent acts and omissions in an amount of no less than \$500,000 for combined property damage and bodily injury to or death of one or more persons in any one accident or occurrence.
- B. The owner of a multi-family home which is four or fewer units, one of which is owner-occupied, shall maintain liability insurance for negligent acts and omissions in an amount of no less than \$300,000 for combined property damage and bodily injury to or death of one or more persons in any one accident or occurrence.
- C. The insurance requirements set forth herein may be superseded by any future amendment to N.J.S.A. 40A:10A-1.

§11-11.4 Violations and Penalties.

Any owner of a business, the owner of a rental unit or units, and the owner of a multi-family home of four or fewer units, one of which is owner-occupied which fails to comply with the provisions of this Chapter and N.J.S.A. 40A:10A-1 (P.L. 2022, c.92), as may be amended, shall be subject to a fine of not less than \$500.00 but no more than \$5,000.00; which may be collected by the Township through a summary proceeding pursuant to the Penalty Enforcement Law of 1999, N.J.S.A. 2A:58-10 et seq.

BE IT FURTHER ORDAINED by the Council of the Borough of Watchung that should any section, paragraph, sentence, clause, or phrase of this Ordinance be declared unconstitutional or invalid for any reason, the remaining portions of this Ordinance shall not be affected thereby and shall remain in full force and effect, and to that end the provisions of this Ordinance are hereby declared to be severable; and

BE IT FURTHER ORDAINED by the Council of the Borough of Watchung that in the event of any inconsistencies between the provisions of this Ordinance and any prior ordinance of the Borough of Watchung, the provisions hereof shall be determined to govern, and the

**BOROUGH OF WATCHUNG
ORDINANCE NO. 24/13**

inconsistencies of the prior ordinance are hereby repealed. All other parts, portions and provisions of the Ordinances of the Borough of Watchung are hereby ratified and confirmed, except where inconsistent with the terms hereof; and

BE IT FURTHER ORDAINED by the County of the Borough of Watchung that within five (5) days after its adoption by the Council, this Ordinance shall be presented to the Mayor for his approval and signature, which approval shall be granted or denied within ten (10) days of receipt of same, pursuant to N.J.S.A. 40A:60-5(d). If the Mayor fails to return this Ordinance with either his approval or objection to same within ten (10) days after it has been presented to him, then this Ordinance shall be deemed approved; and

BE IT FURTHER ORDAINED by the Council of the Borough of Watchung that this Ordinance shall take effect upon final passage and publication according to law; and approval by the Mayor pursuant to N.J.S.A. 40A:60-5(d).

INTRODUCED BY: GIBBS
PASSED: JULY 18, 2024
PUBLISHED: JULY 25, 2024
ADOPTED:
CC: T. MCNULTY, B.HANCE,
COURTS, GENERAL CODE,

ATTEST:

BOROUGH OF WATCHUNG

Edith G. Gil, Borough Clerk

By: _____
Ronald Jubin, Ph.D., Mayor

July 18, 2024

To: Borough of Watchung

15 Mountain Blvd.

Watchung, NJ 07069

Attn: Mr. James Damato

From: Lynn M.K. Franklin

[REDACTED]

Watchung, NJ 07069-5814

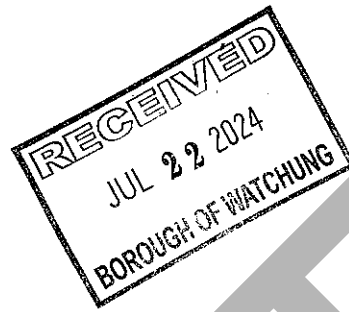

This is a follow-up letter to a request I made via a letter (enc.) dated April 5, 2024. The request was to place teal ribbons and ovarian cancer awareness signs around Watchung Lake and Borough Hall during September, national ovarian cancer awareness month.

I have yet to receive a response to my request. After 3 ½ months I think it reasonable by now to at least be notified of Council action on my request. The permit application for signage has been completed via Ms. Carolyn Taylor.

My husband has checked Council meeting agendas and Council minutes since early April, 2024, and has found nothing related to this request.

Please expedite my request ASAP. Thank you.

Regards,

Lynn M.K. Franklin

[REDACTED]

April 5, 2024

To: Borough of Watchung

15 Mountain Blvd.

Watchung, NJ 07069

From: Lynn M.K. Franklin

[REDACTED]
Watchung, NJ 07069-5814

I request approval to place ovarian cancer awareness signs and teal ribbons on Borough property around Watchung Lake and Borough Hall for the month of September, 2024.

September is National Ovarian Cancer Awareness month. Teal is the awareness color for ovarian cancer.

Lynn Stahl [REDACTED] and I will be placing the signs.

Please let me know if there is more information needed.

Please process this request through the appropriate Board/committee/commission and then notify me when approval has been granted.

Thank you.

Regards,



Lynn M.K. Franklin

[REDACTED]

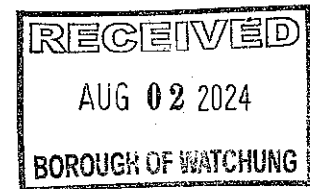

**BOROUGH OF WATCHUNG
PLANNING BOARD
NOTICE OF HEARING**

TAKE NOTICE, that on August 20, 2024 at 7:30 p.m. a public hearing will be held before the Borough of Watchung Planning Board (“Planning Board”) at the Council Chamber of the Watchung Municipal Building, 15 Mountain Boulevard, Watchung, New Jersey to consider the request of the applicant Bonnie Burn Redevelopers Urban Renewal, LLC (“Applicant”) for the following:

to amend the Planning Board’s resolution PB 24-R5, adopted by the Board on January 31, 2024, and, in particular, Findings 1, 12 and 13 of that Resolution, for the construction of a 230-unit inclusionary multi-family housing development, as more fully described below (“Project”), on property located at Bonnie Burn Road, also identified on the Borough of Watchung Tax Map as Block 7401, Lots 19.01 and 19.02, and Block 7403, Lots 5 and 10 (collectively, the “Property”). Specifically, the Application seeks amendment of Findings 1, 12 and 13, and any other related conditions of the Planning Board’s January 31, 2024 resolution that require the construction of a left turn lane on Bonnie Burn Road at the Project entrance.

By way of background, the Planning Board’s October 27, 2021 and January 18, 2022 resolutions initially granted an application for preliminary and final site plan approval for the construction of the Project, an inclusionary multi-family housing development consisting of six residential buildings containing 230 units, of which 46 units are to be set aside for low, very low and moderate income households, together with associated common and amenity space, including a clubhouse, outdoor swimming pool, dog run, children’s recreational area, parking spaces, landscaping, stormwater management improvements and other related site improvements. On July 24, 2023, the Applicant filed an application to amend the site plan approvals granted by the October 27, 2021 and January 18, 2022 resolutions to, inter alia, amend the offsite intersection design on Bonnie Burn Road to eliminate the construction of a traffic signal, which application the Planning Board’s January 31, 2024 resolution approved. The approval for the Project in the Planning Board’s January 31, 2024 resolution required the construction of off-tract roadway improvements, including but not limited to, the installation of left turn lane at the intersection of Bonnie Burn Road and the Project entrance road. The Applicant now seeks amendment of the Planning Board’s resolution PB 24-R5 to provide for an alternative intersection design, as approved by Somerset County, which eliminates a left turn lane into the Project site and, instead widens the roadway, such modification to be subject to an easement with the adjoining property owner, to allow for the construction of the intersection with signs on the adjoining owner’s land.

The Applicant’s supporting documents are on file with the Secretary of Watchung Planning Board and may be inspected at the Watchung Municipal Building, 15 Mountain Boulevard, Watchung, New Jersey in the Planning Department, during regular business hours and may also be available from the Borough’s website.

July 23, 2024

By: Nicole B. Dory, Esq.
Connell Foley LLP
56 Livingston Ave
Roseland, NJ 07068
Attorney for the Applicant

DRAFT

Public Service Electric and Gas Company
Delivery Projects & Construction – Permitting
4000 Hadley Road, 2nd Floor
South Plainfield, NJ 07080



July 25, 2024

Borough of Watchung
Borough Clerk
15 Mountain Boulevard
Watchung, New Jersey 07069

Re: PSE&G BIN0027 - OH ROW Bridge Replacement Roseland-Metuchen
Public Service Electric and Gas Company
Applications for: FWW GP#10A – Very Minor Road Crossing
FHA Verification
FHA Individual Permit

Block 73.02, Lot 16
Valley Road
Borough of Watchung, Somerset County, New Jersey

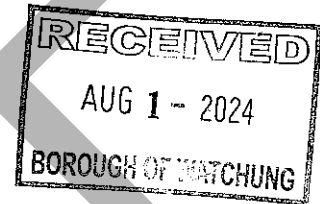

Dear Sir/Madam:

This letter is to provide you with legal notification that Public Service Electric and Gas Company (PSE&G) is submitting to the State of New Jersey Department of Environmental Protection Division of Land Resource Protection, the Application referenced above. The Applicant is proposing to replace an existing but severely dilapidated wooden bridge located within the ROW as well as expand slightly a section of permanent stone access road within the ROW between Valley Road and the proposed replaced bridge.

The complete application package is being provided to you so that interested parties may review the application at your office. Alternatively, any interested person may call NJDEP at (609) 777-0456 to make an appointment to view the application at the NJDEP Office in Trenton.

As part of the review of this application, NJDEP personnel may perform a site inspection. This inspection would involve only that area within a maximum of 150 feet from the border of the Site. The inspection would involve a visual inspection and possibly minor soil borings using a 4-inch diameter hand auger. The inspection would not result in any damage to the vegetation or improvements on residents' property.

The complete permit application package can be reviewed at the municipal clerk's office in the municipality in which the site subject to the application is located or by appointment at the Department's Trenton Office. The Department of Environmental Protection welcomes comments and any information that you may provide concerning the proposed development and site. Please submit your written comments within 15 calendar days of receiving this letter to:

**New Jersey Department of Environmental Protection
Division of Land Use Regulation
P.O. Box 420, Code 501-02A
Trenton, New Jersey 08625
Attn: Borough of Watchung, Somerset County Supervisor**

En 6
Planning
Zoning
ON FILE

As required, one complete copy of the entire application package is also being provided. The NJDEP will notify the Municipal Clerk of the final decision of this application.

If you have any questions or require additional information, please contact me at (609) 558-1349 or by email at Matthew.Kolodziej@pseg.com. Thank you for your assistance in this matter.

Very truly yours,

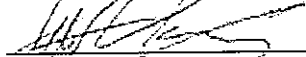

Matthew Kolodziej
PSE&G – Licensing and Permitting
Electric Transmission and Distribution

enclosure

- c: Borough of Watchung Planning Board (w/site plan only)
- Borough of Watchung Construction Department (w/site plan only)
- Borough of Watchung Environmental Commission (w/site plan only)
- Somerset County Planning Board (w/site plan only)
- Somerset-Union SCD (w/site plan only)
- Property Owners within 200' (w/site plan only)

DRAFT

Timothy K. McHugh, Esq.
(610) 301-9072 (Phone)

August 9, 2024

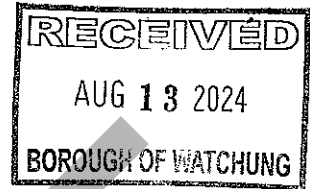

VIA US MAIL

Municipal Clerks, Clerks of the
Board of County Commissioners,
and, where appropriate, Executive
Officers of the Board of County
Commissioners for the Municipalities
and Counties of New Jersey Served by
Jersey Central Power & Light Company

**Re: In the Matter of the 2024/2025 Annual Compliance Filings for a Change in the
Statewide Electric and Gas Permanent Universal Service Fund Program Factors
within the Electric and Gas Societal Benefits Charges Rates Pursuant to N.J.S.A.
48:2-21 and N.J.S.A. 48:2-21.1**

BPU Docket No. ER24070486

Dear Sir/Madam:

Enclosed please find a copy of a Notice of Public Hearing regarding Jersey Central Power & Light Company's ("JCP&L" or the "Company") annual Universal Service Fund ("USF") compliance filing.

PLEASE TAKE NOTICE that the New Jersey Board of Public Utilities has scheduled virtual public hearings on this matter at the times set forth in the enclosed Public Notice.

A copy of the filing is also posted on the Company's website at:

https://www.firstenergycorp.com/jersey_central_power_light/regulatory.html

JCP&L would be pleased to furnish you with any assistance or additional information that you might reasonably require.

Very truly yours,

A handwritten signature in black ink, appearing to read "Timothy K. McHugh".

Timothy K. McHugh
Counsel for Jersey Central Power & Light Company

5

**NOTICE
TO THE CUSTOMERS OF
JERSEY CENTRAL POWER & LIGHT COMPANY**

**Notice of a Filing
and Notice of Public Hearings**

**In the Matter of the 2024/2025 Annual Compliance Filings for a Change in the Statewide
Electric and Gas Permanent Universal Service Fund Program
Factors within the Electric and Gas Societal Benefits Charges Rates Pursuant to
N.J.S.A. 48:2-21 and N.J.S.A. 48:2-21.1**

BPU Docket No. ER24070486

PLEASE TAKE NOTICE that, on June 28, 2024, Jersey Central Power & Light Company (“JCP&L” or “Company”) made an Annual Compliance Filing (“Filing”) with the New Jersey Board of Public Utilities (“Board”) providing supporting documentation for changes in the Universal Service Fund (“USF”) and Lifeline components of JCP&L’s Societal Benefits Charges (“SBC”) to become effective on October 1, 2024. The requested changes in electric USF/Lifeline components are made pursuant to Board Orders at Docket Nos. EX00020091, EO09060506, and EO09090771, and includes the recovery of funding for the USF Program through uniform statewide rates.

The USF Program was established by the Board in 2003, pursuant to the Electric Discount and Energy Competition Act, N.J.S.A. 48:3-49, *et seq.*, (“EDECA”), to assist qualifying low-income individuals in paying their energy bills. The SBC also includes funding for the Lifeline program, which provides assistance with heating costs to qualifying elderly and disabled persons. The State of New Jersey’s Department of Community Affairs (“DCA”) is the Administrator of the USF Program, and the New Jersey Department of Human Services (“DHS”) is the Administrator of the Lifeline programs. DCA and DHS authorize the disbursement of benefits to eligible customers in the respective programs.

Based upon the results and available estimates known to date for the 2023/2024 USF program year, and the available estimates for the 2024/2025 USF program year, it is anticipated that the USF rates will be set to collect \$236.5 million, of which approximately \$143.8 million would be recovered through electric rates with the remaining \$92.7 million recovered through gas rates on a statewide basis. The Lifeline rates are anticipated to collect \$74.6 million, of which, \$49.2 million would be recovered through electric rates with the remaining \$25.4 million recovered through gas rates on a statewide basis.

The current combined rate, after sales and use tax (“SUT”), for the USF and Lifeline programs for electric customers is \$0.002069 per kilowatt-hour (“kWh”). As proposed, the USF component would increase by \$0.000887 per kWh and the Lifeline component would increase by \$0.000013 per kWh. The proposed after-SUT USF/Lifeline program charge will increase to \$0.002969 per kWh.

The proposed statewide charges for electric customers are as follows:

Universal Service/Lifeline Fund Components of Societal Benefits Charge				
	Present	Present (Incl. SUT)	Proposed	Proposed (Incl. SUT)
USF-Electric per kWh	\$0.001243	\$0.001325	\$0.002075	\$0.002212
Lifeline-Electric per kWh	\$0.000698	\$0.000744	\$0.000710	\$0.000757
Total USF/Lifeline per kWh	\$0.001941	\$0.002069	\$0.002785	\$0.002969

The above requests will not result in any profit to JCP&L. The revenues received under the proposed USF and Lifeline program factors are designed to permit the Company to recover its costs associated with these programs only. Actual program costs will be reconciled with the revenues received through the USF and Lifeline program charges in the next scheduled annual USF and Lifeline compliance filing to be made no later than July 1, 2025.

If approved by the Board, the effect of the proposed changes in the electric combined USF/Lifeline Program charges on a typical residential electric bill is illustrated below:

Impact of Proposed USF and Lifeline Charges On Typical Residential Electric Bills					
Monthly kWh Usage	Annual kWh Usage	Present Annual Bill ⁽¹⁾	Proposed Annual Bill ⁽²⁾	Proposed Annual Increase	Proposed % Increase
500	6,000	\$998.04	\$1,003.44	\$5.40	0.54%
1,000	12,000	\$2,055.00	\$2,065.80	\$10.80	0.53%
1,500	18,000	\$3,139.56	\$3,155.76	\$16.20	0.52%

⁽¹⁾ Based on Residential Full Service (RS) rates in effect June 1, 2024

⁽²⁾ Based on Residential Full Service (RS) rates in effect June 1, 2024, with proposed charges

As set forth above, based on JCP&L's Filing, a residential electric customer using 500 kilowatt hours per month, and 6,000 kilowatt hours on an annual basis, would see an increase in their annual bill from \$998.04 to \$1,003.44 or \$5.40 or approximately 0.54%.

The percentage of change applicable to specific customers will vary according to the applicable service classification and the level of the customer's usage.

The Board has the statutory authority pursuant to N.J.S.A. 48:2-21 to establish the USF and Lifeline charges at levels it finds just and reasonable. Therefore, the Board may establish the USF and Lifeline charges at levels other than those proposed by JCP&L's Filing. As a result, the above-described charges may increase or decrease based upon the Board's decision.

Copies of the Filing can be reviewed on JCP&L's website at:

https://www.firstenergycorp.com/jersey_central_power_light/regulatory.html.

PLEASE TAKE FURTHER NOTICE that virtual public hearings will be conducted on the following date and times so that members of the public may present their views on the Filing:

VIRTUAL PUBLIC HEARINGS

Date: September 3, 2024

Hearing Times: 4:30 P.M. and 5:30 P.M.

Join from the meeting link:

Link: <https://fecorp.co/PH-09-03-2024>

Meeting ID: 212 975 853 357

Passcode: DDc8Ry

-or-

Join by phone:

Dial-In Number: 878-787-7704

Phone Conference ID: 387 080 913

Representatives from the Company, Board Staff, and the New Jersey Division of Rate Counsel will participate in the virtual public hearings. Members of the public are invited to participate by utilizing the link or dial-in information set forth above and may express their views on this Filing. All comments will be made a part of the final record of this proceeding and will be considered by the Board. To encourage full participation in this opportunity for public comment, please submit any request for needed accommodations, such as interpreters and/or listening devices, 48 hours prior to the above hearings to the Board Secretary at board.secretary@bpu.nj.gov.

The Board will also accept written and/or electronic comments. Comments may be submitted directly to the specific docket number listed above using the "Post Comments" button on the Board's Public Document Search tool at <https://publicaccess.bpu.state.nj.us/>. Comments are considered public documents for purposes of the State's Open Public Records Act. Only documents that are intended to be public should be submitted using the "Post Comments" button on the Board's Public Document Search tool. Any confidential information should be submitted in accordance with the procedures set forth in N.J.A.C. 14:1-12.3. In addition to hard copy submissions, confidential information may also be filed electronically via the Board's e-filing system or by email to the Secretary of the Board, Sherri L. Golden. Please include "Confidential Information" in the subject line of any email. Instructions for confidential e-filing are found on the Board's webpage at <https://www.nj.gov/bpu/agenda/efiling/>.

Emailed and/or written comments may also be submitted to:

Sherri L. Golden, Secretary of the Board

44 South Clinton Avenue, 1st Floor

P.O. Box 350

Trenton, NJ 08625-0350

Phone: (609) 913-6241

Email: board.secretary@bpu.nj.gov

All comments should include the name of the matter referenced above and the assigned docket number.

**BOROUGH OF WATCHUNG
RESOLUTION: R1**

WHEREAS, Section 2-25.13 of the Code of the Borough of Watchung requires that contracts for purchases or services involving more than the authorized bid threshold be awarded by a resolution of the Mayor and Council.

NOW, THEREFORE, BE IT RESOLVED by the Mayor and Council of the Borough of Watchung, County of Somerset, State of New Jersey, that the Purchasing Agent be authorized to issue Purchase Orders as follows:

Vendor: BL Contracting, Inc., 5 Marguerite Lane, Towaco, NJ 07082
Item: Watchung Library Asbestos Abatement
Total Price: \$16,500.00
Charged to: C-02-110-A13

Vendor: Winner Ford, 250 Haddonfield-Berline Road, Cherry Hill, NJ 08034
Item: (2) 2025 Ford Interceptor SUV, V6
Total Price: \$88,386.00
Charged to: 4-01-190-223

Vendor: Axon Enterprise, Inc., 17800 N 85th Street, Scottsdale, AZ 85255
Item: Year 2 BWC, Redaction, Respond+
Total Price: \$43,302.29
Charged to: 4-01-190-271

Christine B. Ead, Council President

Ronald Jubin, Ph.D., Mayor

ADOPTED: AUGUST 15, 2024
INDEX: PURCHASING
C: B. HANCE

BOROUGH OF WATCHUNG
 15 Mountain Boulevard
 Watchung, NJ 07069
 TEL (908)756-0080 FAX (908)757-7027

PURCHASE ORDER	
THIS NUMBER MUST APPEAR ON ALL INVOICES, PACKING LISTS, CORRESPONDENCE, ETC.	
NO.	24-00845

SHIP TO	WATCHUNG MUNICIPAL BUILDING 15 MOUNTAIN BLVD. WATCHUNG, NJ 07069-6399
	VENDOR #: BLCONTRA BL Contracting Inc. 5 Marguerite Lane Towaco, NJ 07082 Phone: (973)901-0153

ORDER DATE: 07/22/24
 REQUISITION NO:
 DELIVERY DATE:
 STATE CONTRACT:
 ACCOUNT NUM:

PAYMENT RECORD	
CHECK NO.	
DATE PAID	

NOTICE: TAX ID #22-6002382 - TAX EXEMPT

QTY/UNIT	DESCRIPTION	ACCOUNT NO.	UNIT PRICE	TOTAL COST
1.00	Watchung Library asbestos abatement	C-02- -110-A13	16,500.0000	16,500.00
			TOTAL	16,500.00

CLAIMANT'S CERTIFICATION & DECLARATION	OFFICER'S CERTIFICATION	APPROVAL TO PURCHASE
<p>I do solemnly declare and certify under penalties of the law that the within bill is correct in all its particulars; that the articles have been furnished or services rendered as stated therein; that no bonus has been given or received by any person or persons within the knowledge of this claimant in connection with the above claim; that the amount therein stated is justly due and owing; and that the amount charged is a reasonable one.</p> <p>X</p> <p>_____ VENDOR SIGN HERE</p> <p>_____ OFFICIAL POSITION DATE</p> <p>_____ TAX ID NO. OR SOCIAL SECURITY NO.</p>	<p>I, having knowledge of the facts, certify that the materials and supplies have been received or the services rendered; said certification being based on signed delivery slips or other reasonable procedures.</p> <p>_____ DEPT. HEAD DATE</p> <p>VENDOR MUST SIGN CERTIFICATION STATEMENT ON THIS VOUCHER. MAIL VOUCHER & ITEMIZED BILLS TO: BOROUGH OF WATCHUNG 15 Mountain Boulevard Watchung, NJ 07069</p>	<p>DO NOT ACCEPT THIS ORDER UNLESS IT IS SIGNED BELOW.</p> <p><i>William J. Annce</i> _____ CFO/QPA</p> <p>_____ COUNCIL APPROVAL CAN BE SEEN</p> <p>_____ ON BILL LIST RESOLUTION</p>

BOROUGH OF WATCHUNG
 15 Mountain Boulevard
 Watchung, NJ 07069
 TEL (908)756-0080 FAX (908)757-7027

PURCHASE ORDER	
THIS NUMBER MUST APPEAR ON ALL INVOICES, PACKING LISTS, CORRESPONDENCE, ETC.	
NO.	24-00837

SHIP TO	WATCHUNG POLICE DEPARTMENT 840 SOMERSET STREET WATCHUNG, NJ 07069-4952 ATTN: SERVICE DIVISION
	VENDOR #: WF WINNER FORD 250 HADDONFIELD-BERLIN RD CHERRY HILL, NJ 08034

ORDER DATE: 07/22/24
 REQUISITION NO: RR400517
 DELIVERY DATE:
 STATE CONTRACT: A87527
 ACCOUNT NUM:

PAYMENT RECORD	
CHECK NO.	
DATE PAID	

NOTICE: TAX ID #22-6002382 - TAX EXEMPT

QTY/UNIT	DESCRIPTION	ACCOUNT NO.	UNIT PRICE	TOTAL COST
2.00	2025 Ford Interceptor SUV V6 color: Black 99B: V6, 44U, 60R, 59B, 21L, 68G, 51T, 18D	4-01- -190-223	44,193.0000	88,386.00
			TOTAL	88,386.00

CLAIMANT'S CERTIFICATION & DECLARATION	OFFICER'S CERTIFICATION	APPROVAL TO PURCHASE
I do solemnly declare and certify under penalties of the law that the within bill is correct in all its particulars; that the articles have been furnished or services rendered as stated therein; that no bonus has been given or received by any person or persons within the knowledge of this claimant in connection with the above claim; that the amount therein stated is justly due and owing; and that the amount charged is a reasonable one. X _____ VENDOR SIGN HERE _____ OFFICIAL POSITION DATE _____ TAX ID NO. OR SOCIAL SECURITY NO.	I, having knowledge of the facts, certify that the materials and supplies have been received or the services rendered; said certification being based on signed delivery slips or other reasonable procedures. _____ DEPT. HEAD DATE VENDOR MUST SIGN CERTIFICATION STATEMENT ON THIS VOUCHER. MAIL VOUCHER & ITEMIZED BILLS TO: BOROUGH OF WATCHUNG 15 Mountain Boulevard Watchung, NJ 07069	DO NOT ACCEPT THIS ORDER UNLESS IT IS SIGNED BELOW. _____ CFQ/QPA _____ COUNCIL APPROVAL CAN BE SEEN _____ ON BILL LIST RESOLUTION

BOROUGH OF WATCHUNG
 15 Mountain Boulevard
 Watchung, NJ 07069
 TEL (908)756-0080 FAX (908)757-7027

PURCHASE ORDER	
THIS NUMBER MUST APPEAR ON ALL INVOICES, PACKING LISTS, CORRESPONDENCE, ETC.	
NO.	24-00900

SHIP TO	WATCHUNG POLICE DEPARTMENT 840 SOMERSET STREET WATCHUNG, NJ 07069-4952 ATTN: SERVICE DIVISION
	VENDOR #: AXONENTE Axon Enterprise, Inc. 17800 N 85th Street Scottsdale, AZ 85255 Phone: (800)978-2739

ORDER DATE: 08/08/24
 REQUISITION NO: RR400557
 DELIVERY DATE:
 STATE CONTRACT:
 ACCOUNT NUM:

PAYMENT RECORD	
CHECK NO.	
DATE PAID	

NOTICE: TAX ID #22-6002382 - TAX EXEMPT

QTY/UNIT	DESCRIPTION	ACCOUNT NO.	UNIT PRICE	TOTAL COST
1.00	Year 2 BWC,Redaction,Respond+ Invoice # INUS268910	4-01- -190-271	43,302.2900	43,302.29
			TOTAL	43,302.29

CLAIMANT'S CERTIFICATION & DECLARATION	OFFICER'S CERTIFICATION	APPROVAL TO PURCHASE
<p>I do solemnly declare and certify under penalties of the law that the within bill is correct in all its particulars; that the articles have been furnished or services rendered as stated therein; that no bonus has been given or received by any person or persons within the knowledge of this claimant in connection with the above claim; that the amount therein stated is justly due and owing; and that the amount charged is a reasonable one.</p> <p>X</p> <p>_____ VENDOR SIGN HERE</p> <p>_____ OFFICIAL POSITION DATE</p> <p>_____ TAX ID NO. OR SOCIAL SECURITY NO.</p>	<p>I, having knowledge of the facts, certify that the materials and supplies have been received or the services rendered; said certification being based on signed delivery slips or other reasonable procedures.</p> <p>_____ DEPT. HEAD DATE</p> <p>VENDOR MUST SIGN CERTIFICATION STATEMENT ON THIS VOUCHER. MAIL VOUCHER & ITEMIZED BILLS TO: BOROUGH OF WATCHUNG 15 Mountain Boulevard Watchung, NJ 07069</p>	<p>DO NOT ACCEPT THIS ORDER UNLESS IT IS SIGNED BELOW.</p> <p><i>William J. Hance</i> _____ CFO/QPA</p> <p>_____ COUNCIL APPROVAL CAN BE SEEN</p> <p>_____ ON BILL LIST RESOLUTION</p>

**BOROUGH OF WATCHUNG
RESOLUTION: R2**

WHEREAS, a duplicate tax payment was made by Bradley Lubeck and he is requesting a refund.

NOW, THEREFORE BE IT RESOLVED by the Mayor and Council of the Borough of Watchung, County of Somerset, State of New Jersey that the refund of said payments be made per the details listed below:

Block 1101 Lot 3.01 40 Reynolds Drive
Bradley Lubeck
Amount: \$5,486.84

Christine B. Ead, Council President

Ronald Jubin, Ph.D., Mayor

ADOPTED: AUGUST 15, 2024
INDEX: FINANCE-MISC,
C: B.HANCE,

BOROUGH OF WATCHUNG
RESOLUTION:R3

BE IT RESOLVED, by the Mayor and Council of the Borough of Watchung,
that the Borough Treasurer be, and is hereby directed to pay bills in the amount of \$7,141,620.57
per the attached bill list. The expenditures can be broken down into the following categories:

Affordable Housing Trust	\$	1,311.00
Animal Control	\$	7.80
Assessment Trust Fund	\$	7,750.05
Developer Escrow	\$	10,568.73
Other Escrow	\$	97,479.30
Somerset County Taxes	\$	1,950,543.78
Capital Fund	\$	139,558.88
Grant Fund	\$	5,474.45
Watchung Borough Board of Education	\$	1,517,415.00
Watchung Hills Regional High School	\$	671,896.00
Current Fund	\$	3,012,615.58
Total:	\$	7,414,620.57

_____ Robert Gibbs	_____ Curt Dahl
_____ Paul Fischer	_____ Paolo Marano
_____ Christine Ead, Council President <i>Christine Ead</i>	_____ Sonia Abi Habib
_____ William J. Hance, CFO <i>William J. Hance</i>	_____ Ronald Jubin, Mayor
_____ James Damato, Administrator	

Date: 08/15/2024
Index: Finance

Range of Checking Accts: AFFORD HOUSING to WIRE TRANSFER Range of Check Dates: 07/12/24 to 08/08/24
Report Type: All Checks Report Format: Detail Check Type: Computer: Y Manual: Y Dir Deposit: Y

Check #	Check Date	Vendor	Amount Paid	Charge Account	Account Type	Reconciled/Void	Ref Num
PO #	Item	Description				Contract	Ref Seq Acct
AFFORD HOUSING AFFORDABLE HOUSING TRUST FUND							
709	08/08/24	BATEM DIFRANCESCO, BATEMAN, COLEY,					5872
24-00023	47	affordable housing	87.50	H-06- -100-101	Budget		2 1
				Affordable Housing Trust Fund			
710	08/08/24	CGPH CGP&H					5872
22-00826	22	affordable housing admin agent	1,223.50	H-06- -100-101	Budget		1 1
				Affordable Housing Trust Fund			
Checking Account Totals							
		<u>Paid</u>	<u>Void</u>	<u>Amount Paid</u>	<u>Amount Void</u>		
		Checks: 2	0	1,311.00	0.00		
		Direct Deposit: 0	0	0.00	0.00		
		Total: 2	0	1,311.00	0.00		
ANIMAL CONTROL Investors Animal Control Trust							
1103	08/08/24	NJDHS NJ DEPT OF HEALTH & SENIOR SER					5873
24-00016	8	July dog lic #172-176	7.80	D-11- -100-201	Budget		1 1
				Animal Control Trust Fund			
Checking Account Totals							
		<u>Paid</u>	<u>Void</u>	<u>Amount Paid</u>	<u>Amount Void</u>		
		Checks: 1	0	7.80	0.00		
		Direct Deposit: 0	0	0.00	0.00		
		Total: 1	0	7.80	0.00		
ASSESSMENT Investors Assessment Trust							
22	08/07/24	USBANKNA NJEIT c/o US Bank Nat. Assoc.					5870
24-00877	3	NJEIT Loan 2024	7,750.05	A-04- -655-283	Budget		1 1
				Pmt Of Bond Principal			
Checking Account Totals							
		<u>Paid</u>	<u>Void</u>	<u>Amount Paid</u>	<u>Amount Void</u>		
		Checks: 1	0	7,750.05	0.00		
		Direct Deposit: 0	0	0.00	0.00		
		Total: 1	0	7,750.05	0.00		
CAPITAL ACCOUNT Investors Savings Capital Fund							
2373	08/05/24	MTMETRO MTM Metro Corp.					5867
24-00598	1	removal & disposal of asbestos	89,000.00	C-02- -244-A11	Budget		1 1
				watchung Library Improvements 24/04			
24-00598	2	change order - plaster removal	12,000.00	C-02- -244-A11	Budget		2 1
				watchung Library Improvements 24/04			
			101,000.00				
2374	08/08/24	BLCONTRA BL Contracting Inc.					5874
24-00845	1	Watchung Library asbestos	16,500.00	C-02- -110-A13	Budget		1 1
				Soft Costs			
2375	08/08/24	REMINGTO Remington & Vernick Engineers					5874
24-00874	1	July engineering	12,988.88	C-02- -104-A11	Budget		2 1
				2021 Roadway Improvements			

Check #	Check Date	Vendor	Amount Paid	Charge Account	Account Type	Reconciled/Void Contract	Ref Num
PO #	Item	Description					Ref Seq Acct
CAPITAL ACCOUNT Investors Savings Capital Fund Continued							
2375 Remington & Vernick Engineers Continued							
24-00875	1	July Engineering Services	9,070.00	C-02- -110-A13 Soft Costs	Budget		3 1
			<u>22,058.88</u>				
Checking Account Totals							
			<u>Paid</u>	<u>Void</u>	<u>Amount Paid</u>	<u>Amount Void</u>	
		Checks:	3	0	139,558.88	0.00	
		Direct Deposit:	0	0	0.00	0.00	
		Total:	3	0	139,558.88	0.00	
CURRENT FUND Investors Bank Current Fund							
575	07/31/24	BEL VERIZON					5868
24-00882	1	phone services	887.68	4-01- -283-459 Telephone	Budget		1 1
24-00882	2	phone services	292.59	4-01- -283-459 Telephone	Budget		2 1
24-00882	3	phone services	298.31	4-01- -283-459 Telephone	Budget		3 1
24-00882	4	phone services	922.78	4-01- -283-459 Telephone	Budget		4 1
24-00882	5	phone services	292.59	4-01- -283-459 Telephone	Budget		5 1
24-00882	6	phone services	298.96	4-01- -283-459 Telephone	Budget		6 1
			<u>2,992.91</u>				
576	07/31/24	ONSTAR Onstar					5868
24-00012	6	onstar service Chevy Bolt	85.28	4-01- -155-273 Bldg.-Other Contracted Serv.	Budget		7 1
577	07/31/24	RPO U.S. POSTAL SERVICE					5868
24-00879	1	postage	2,000.00	4-01- -115-257 Postage Expense	Budget		8 1
578	07/31/24	SHERWEB Sherweb					5868
24-00635	4	Azure Plan	195.00	4-01- -115-233 Computer Expenses	Budget		9 1
24-00635	5	Azure Plan	189.00	4-01- -115-233 Computer Expenses	Budget		10 1
			<u>384.00</u>				
579	07/31/24	TRANSFIR Transfirst					5868
24-00010	10	credit card	256.52	4-01- -405-282 Specialized Services	Budget		11 1
24-00010	11	credit card	246.70	4-01- -405-282 Specialized Services	Budget		12 1
24-00010	12	credit card	187.00	4-01- -405-282 Specialized Services	Budget		13 1
24-00010	13	credit card	280.64	4-01- -405-282 Specialized Services	Budget		14 1
			<u>970.86</u>				

Check #	Check Date	Vendor	Amount Paid	Charge Account	Account Type	Reconciled/Void Contract	Ref Num	Ref Seq	Num Acct
CURRENT FUND		Investors Bank Current Fund		Continued					
580	07/31/24	WAT01 WATCHUNG BORO. PAYROLL ACCT.					5868		
24-00867	1	Watchung Boro Payroll	1,732.75	4-01- -160-111 Salary & Wage	Budget		15	1	
24-00867	2	Watchung Boro Payroll	2,083.33	4-01- -190-111 Salary & Wage	Budget		16	1	
24-00867	3	Watchung Boro Payroll	277.95	4-01- -200-111 Salary & Wage	Budget		17	1	
24-00867	4	Watchung Boro Payroll	11,116.25	4-01- -245-111 Salary & Wage	Budget		18	1	
24-00867	5	Watchung Boro Payroll	759.62	4-01- -255-111 Salary & Wage	Budget		19	1	
24-00867	6	Watchung Boro Payroll	875.00	4-01- -110-111 Salary & Wage	Budget		20	1	
24-00867	7	Watchung Boro Payroll	9,966.66	4-01- -115-111 Salary & Wage	Budget		21	1	
24-00867	8	Watchung Boro Payroll	9,359.13	4-01- -120-111 Salary & Wage	Budget		22	1	
24-00867	9	Watchung Boro Payroll	8,890.66	4-01- -130-111 Salary & Wage	Budget		23	1	
24-00867	10	Watchung Boro Payroll	3,786.58	4-01- -135-111 Salary & Wage	Budget		24	1	
24-00867	11	Watchung Boro Payroll	2,407.66	4-01- -140-111 Salary & Wage	Budget		25	1	
24-00867	12	Watchung Boro Payroll	2,529.75	4-01- -150-111 Salary & Wages	Budget		26	1	
24-00867	13	Watchung Boro Payroll	12,462.41	4-01- -205-111 Salary & Wage	Budget		27	1	
24-00867	14	Watchung Boro Payroll	178.22	4-01- -205-111 Salary & Wage	Budget		28	1	
24-00867	15	Watchung Boro Payroll	2,700.00	4-01- -187-111 Salary & Wage	Budget		29	1	
24-00867	16	Watchung Boro Payroll	152,650.18	4-01- -190-111 Salary & Wage	Budget		30	1	
24-00867	17	Watchung Boro Payroll	5,362.39	4-01- -190-112 Overtime	Budget		31	1	
24-00867	18	Watchung Boro Payroll	3,538.20	4-01- -190-112 Overtime	Budget		32	1	
24-00867	19	Watchung Boro Payroll	11,933.11	4-01- -205-111 Salary & Wage	Budget		33	1	
24-00867	20	Watchung Boro Payroll	4,261.24	4-01- -205-111 Salary & wage	Budget		34	1	
24-00867	21	Watchung Boro Payroll	299.08	4-01- -205-112 Overtime	Budget		35	1	
24-00867	22	Watchung Boro Payroll	7,514.86	4-01- -250-111 Salary & wage	Budget		36	1	
24-00867	23	Watchung Boro Payroll	1,063.79	4-01- -265-111 Salary & Wage	Budget		37	1	
24-00867	24	Watchung Boro Payroll	2,820.45	4-01- -405-111 Salary & Wage	Budget		38	1	
24-00867	25	Watchung Boro Payroll	10,919.74	4-01- -310-218 Social Security / Medicare	Budget		39	1	

Check #	Check Date	Vendor	Amount Paid	Charge Account	Account Type	Reconciled/Void Contract	Ref Num
PO #	Item	Description					Ref Seq Acct
CURRENT FUND		Investors Bank Current Fund	Continued				
580	WATCHUNG BORO. PAYROLL ACCT.	Continued					
24-00867	26	Watchung Boro Payroll	35.81	4-01- -307-283	Budget		40 1
				DCRP			
24-00867	29	Watchung Boro Payroll	291.67	4-01- -190-111	Budget		41 1
				Salary & Wage			
24-00867	30	Watchung Boro Payroll	2,540.08	4-01- -190-111	Budget		42 1
				Salary & Wage			
24-00867	31	Watchung Boro Payroll	266.86	4-01- -190-111	Budget		43 1
				Salary & Wage			
			<u>272,040.09</u>				
581	07/31/24	PERS State of New Jersey					5868
24-00040	11	health insurance June Active	213,495.40	4-01- -175-393	Budget		44 1
				Health Benefits Plan			
24-00040	12	health insurance July Active	183,395.13	4-01- -175-393	Budget		45 1
				Health Benefits Plan			
24-00040	13	health insurance June Retired	194,752.96	4-01- -175-393	Budget		46 1
				Health Benefits Plan			
24-00040	14	health insurance July Retired	171,454.63	4-01- -175-393	Budget		47 1
				Health Benefits Plan			
			<u>763,098.12</u>				
582	07/31/24	CLEARFLY Clearfly					5868
24-00030	6	telephone service	10.24	4-01- -283-459	Budget		48 1
				Telephone			
24-00030	7	telephone service	360.06	4-01- -283-459	Budget		49 1
				Telephone			
			<u>370.30</u>				
583	07/31/24	CLEARFLY Clearfly					5868
24-00030	8	telephone service	370.75	4-01- -283-459	Budget		50 1
				Telephone			
584	07/31/24	WAT01 WATCHUNG BORO. PAYROLL ACCT.					5868
24-00827	1	Wachung Boro payroll	2,204.00	4-01- -165-111	Budget		51 1
				Salary & wage			
24-00827	2	Wachung Boro payroll	2,083.33	4-01- -190-111	Budget		52 1
				Salary & Wage			
24-00827	3	Wachung Boro payroll	288.45	4-01- -190-112	Budget		53 1
				Overtime			
24-00827	4	Wachung Boro payroll	277.95	4-01- -200-111	Budget		54 1
				Salary & wage			
24-00827	5	Wachung Boro payroll	9,333.00	4-01- -245-111	Budget		55 1
				Salary & wage			
24-00827	6	Wachung Boro payroll	759.62	4-01- -255-111	Budget		56 1
				Salary & wage			
24-00827	7	Wachung Boro payroll	875.00	4-01- -110-111	Budget		57 1
				Salary & wage			
24-00827	8	Wachung Boro payroll	10,101.81	4-01- -115-111	Budget		58 1
				Salary & wage			
24-00827	9	Wachung Boro payroll	9,359.13	4-01- -120-111	Budget		59 1
				Salary & wage			

Check #	Check Date	Vendor	Amount Paid	Charge Account	Account Type	Reconciled/Void Contract	Ref Num	Ref Seq	Num Acct
CURRENT FUND Investors Bank Current Fund Continued									
584 WATCHUNG BORO. PAYROLL ACCT. Continued									
24-00827	10	Wachung Boro payroll	8,890.66	4-01- -130-111 Salary & Wage	Budget		60	1	
24-00827	11	Wachung Boro payroll	4,550.63	4-01- -135-111 Salary & Wage	Budget		61	1	
24-00827	12	Wachung Boro payroll	2,407.66	4-01- -140-111 Salary & Wage	Budget		62	1	
24-00827	13	Wachung Boro payroll	2,529.75	4-01- -150-111 Salary & Wages	Budget		63	1	
24-00827	14	Wachung Boro payroll	12,462.41	4-01- -205-111 Salary & Wage	Budget		64	1	
24-00827	15	Wachung Boro payroll	2,080.66	4-01- -205-112 Overtime	Budget		65	1	
24-00827	16	Wachung Boro payroll	2,051.00	4-01- -205-111 Salary & Wage	Budget		66	1	
24-00827	17	Wachung Boro payroll	153,571.85	4-01- -190-111 Salary & Wage	Budget		67	1	
24-00827	18	Wachung Boro payroll	14,278.75	4-01- -190-112 Overtime	Budget		68	1	
24-00827	19	Wachung Boro payroll	2,125.20	4-01- -190-112 Overtime	Budget		69	1	
24-00827	20	Wachung Boro payroll	1,083.31	4-01- -190-111 Salary & Wage	Budget		70	1	
24-00827	21	Wachung Boro payroll	11,933.11	4-01- -205-111 Salary & Wage	Budget		71	1	
24-00827	22	Wachung Boro payroll	682.57	4-01- -205-112 Overtime	Budget		72	1	
24-00827	23	Wachung Boro payroll	3,519.00	4-01- -205-112 Overtime	Budget		73	1	
24-00827	24	Wachung Boro payroll	7,514.86	4-01- -250-111 Salary & Wage	Budget		74	1	
24-00827	25	Wachung Boro payroll	1,063.79	4-01- -265-111 Salary & Wage	Budget		75	1	
24-00827	26	Wachung Boro payroll	2,820.45	4-01- -405-111 Salary & Wage	Budget		76	1	
24-00827	27	Wachung Boro payroll	11,107.14	4-01- -310-218 Social Security / Medicare	Budget		77	1	
24-00827	28	Wachung Boro payroll	66.76	4-01- -307-283 DCRP	Budget		78	1	
24-00827	29	Wachung Boro payroll	0.00	4-01- -265-111 Salary & Wage	Budget		79	1	
24-00827	30	Wachung Boro payroll	101.38	4-01- -115-111 Salary & Wage	Budget		80	1	
24-00827	31	Wachung Boro payroll	2,722.50	4-01- -187-111 Salary & Wage	Budget		81	1	
			<u>282,845.73</u>						
585	08/07/24	CITIZEN Citizens Bank					5869		
24-00883	1	Amazon purchases	512.16	4-01- -245-202 Summer Camp	Budget		1	1	

Check #	Check Date	Vendor	Amount Paid	Charge Account	Account Type	Reconciled/Void Contract	Ref Num	Ref Seq	Num Acct
CURRENT FUND		Investors Bank Current Fund	Continued						
585		Citizens Bank							
24-00883		2 Amazon purchases	4,000.00	4-01- -110-278	Budget		2	1	
			<u>4,512.16</u>	Community Relations					
586	08/07/24	RPO U.S. POSTAL SERVICE					5869		
24-00880		1 postage	1,500.00	4-01- -115-257	Budget		3	1	
				Postage Expense					
587	08/07/24	CITIZEN Citizens Bank					5869		
24-00797		1 Amazon Basics LegalFileFolders	60.03	4-01- -190-227	Budget		4	1	
				Office Supplies & Materials					
24-00797		2 USB Charging Cables 2 pk	13.99	4-01- -190-232	Budget		5	1	
				General Supplies, NOC					
24-00797		3 Short USB Charging Cables 2 pk	9.69	4-01- -190-232	Budget		6	1	
				General Supplies, NOC					
24-00797		4 Anker Power bank	35.98	4-01- -190-232	Budget		7	1	
				General Supplies, NOC					
24-00797		5 48"x180' Brown Paper Roll	44.90	4-01- -190-232	Budget		8	1	
				General Supplies, NOC					
24-00797		6 Mission Darkness Farady Bag4pk	90.16	4-01- -190-232	Budget		9	1	
				General Supplies, NOC					
24-00797		7 E310DW Toner LxTek	29.89	4-01- -190-258	Budget		10	1	
				Printing & Binding					
24-00797		8 M506DN Toner Aztech	96.49	4-01- -190-258	Budget		11	1	
				Printing & Binding					
24-00797		9 138X Toner HP	246.74	4-01- -190-258	Budget		12	1	
				Printing & Binding					
24-00797		10 Halyard Nitrile Gloves Small	100.17	4-01- -190-231	Budget		13	1	
				Emergency & Safety Supplies					
24-00800		1 Shotgun Cleaning Kit 12 Gauge	29.99	4-01- -190-232	Budget		14	1	
				General Supplies, NOC					
24-00878		1 email service	335.39	4-01- -190-233	Budget		15	1	
				Computer Expense					
24-00878		2 zoom	159.00	4-01- -110-278	Budget		16	1	
				Community Relations					
24-00878		3 Cimemark trip	428.43	4-01- -245-202	Budget		17	1	
				Summer Camp					
24-00878		4 NCR paper	461.20	4-01- -250-227	Budget		18	1	
				Office Supplies & Materials					
24-00878		5 womens volleyball	71.17	4-01- -245-213	Budget		19	1	
				Volleyball/Men's Softball					
24-00878		6 sheet protectors	7.41	4-01- -120-227	Budget		20	1	
				Office Supplies & Materials					
24-00878		7 varnish	125.67	4-01- -110-278	Budget		21	1	
				Community Relations					
24-00878		8 BJs supplies	67.44	4-01- -245-202	Budget		22	1	
				Summer Camp					
24-00878		9 traffic cones & flags	305.52	4-01- -155-232	Budget		23	1	
				General Supplies					
24-00878		10 traffic cones	211.12	4-01- -155-232	Budget		24	1	
				General Supplies					

Check #	Check Date	Vendor	Amount Paid	Charge Account	Account Type	Reconciled/Void Contract	Ref Num	Ref Seq	Num Acct
CURRENT FUND									
587	08/07/24	Investors Bank		Continued					
24-00878	11	Citizens Bank fire dept amazon supplies	491.73	4-01- -185-231 Emergency & Safety Supplies	Budget		25	1	
24-00878	12	Block party supplies	191.04	4-01- -245-217 Special Events	Budget		26	1	
24-00878	13	fire dept amazon supplies	172.41	4-01- -185-231 Emergency & Safety Supplies	Budget		27	1	
24-00878	14	fire dept amazon supplies	277.21	4-01- -185-231 Emergency & Safety Supplies	Budget		28	1	
24-00878	15	fire dept amazon supplies	20.84	4-01- -185-231 Emergency & Safety Supplies	Budget		29	1	
24-00878	16	zoom	159.00	4-01- -110-278 Community Relations	Budget		30	1	
24-00878	17	monitor memo board	14.96	4-01- -120-227 Office Supplies & Materials	Budget		31	1	
24-00878	18	walgreens banner	41.99	4-01- -110-278 Community Relations	Budget		32	1	
24-00878	19	walgreens photo	44.77	4-01- -110-278 Community Relations	Budget		33	1	
24-00878	20	michaels mat for photos	7.99	4-01- -110-278 Community Relations	Budget		34	1	
24-00878	21	photo print	13.91	4-01- -110-278 Community Relations	Budget		35	1	
24-00878	22	amazon purchases	977.00	4-01- -130-233 Computer Expense	Budget		36	1	
			<u>5,343.23</u>						
588	08/07/24	CMB CHASE MANHATTAN BANK					5869		
24-00013	3	Bond Principal	890,000.00	4-01- -655-201 Payment Of Bond Principal	Budget		37	1	
24-00013	4	Bond Interest	128,887.50	4-01- -660-201 Interest On Bonds	Budget		38	1	
			<u>1,018,887.50</u>						
589	08/07/24	CLEARFLY Clearlyfly					5869		
24-00030	9	telephone service August	384.06	4-01- -283-459 Telephone	Budget		39	1	
590	08/07/24	PITN3 PITNEY BOWES INC					5869		
24-00049	5	meter rental final	19.57	4-01- -115-257 Postage Expense	Budget		40	1	
591	08/07/24	PERS State of New Jersey					5869		
24-00040	15	August active health	3,631.32	4-01- -175-393 Health Benefits Plan	Budget		41	1	
592	08/07/24	USBANKNA NJEIT c/o US Bank Nat. Assoc.					5869		
24-00877	1	NJEIT Loan 2014	17,962.50	4-01- -686-201 NJEIT LOAN PRINCIPAL & INTEREST	Budget		42	1	
24-00877	2	NJEIT Loan 2024	23,250.18	4-01- -686-201 NJEIT LOAN PRINCIPAL & INTEREST	Budget		43	1	

Check #	Check Date	Vendor	Amount Paid	Charge Account	Account Type	Reconciled/Void Contract	Ref Num
PO #	Item	Description					Ref Seq Acct
CURRENT FUND		Investors Bank Current Fund	Continued				
592 NJEIT	c/o	US Bank Nat. Assoc.	Continued				
24-00877	4	admin fee	450.00	4-01- -150-283	Budget		44 1
				Unclassified Expenses			
			<u>41,662.68</u>				
593	08/07/24	RUT RUTGERS UNIVERSITY					5869
24-00876	1	MANAGEMENT TASKS	944.00	4-01- -205-276	Budget		45 1
				Training Aids & Programs			
24-00876	2	MANAGING & DEVELOPING	760.00	4-01- -205-276	Budget		46 1
				Training Aids & Programs			
24-00876	3	PUBLIC RELATIONS	575.00	4-01- -205-276	Budget		47 1
				Training Aids & Programs			
			<u>2,279.00</u>				
42107	08/08/24	ACCSESNJ ACCSES New Jersey, Inc.					5875
24-00032	8	custodial work	4,740.62	4-01- -205-273	Budget		24 1
				Other Contractural Services			
24-00032	9	custodial work	4,740.62	4-01- -155-272	Budget		25 1
				Janitorial & Laundry Serv.			
			<u>9,481.24</u>				
42108	08/08/24	ACDAUGHT AC DAUGHTRY SECURITY SYSTEMS					5875
24-00064	10	SECURITY/FIRE SYSTEM MONITOR	591.87	4-01- -155-273	Budget		33 1
				Bldg.-Other Contracted Serv.			
42109	08/08/24	ADS Action Data Services					5875
24-00024	21	July payroll	460.74	4-01- -130-281	Budget		17 1
				Prof. & Contr. Services-Other			
24-00024	22	July payroll	640.18	4-01- -130-281	Budget		18 1
				Prof. & Contr. Services-Other			
			<u>1,100.92</u>				
42110	08/08/24	AIRGROUP Air Group LLC					5875
24-00067	5	2024 DPW HVAC REPAIRS	699.99	4-01- -155-284	Budget		34 1
				HVAC Repairs			
42111	08/08/24	ANDE2 SCOTT ANDERLE					5875
24-00799	1	Diversion Pant Slim (Black)	125.80	4-01- -190-283	Budget		85 1
				Unclassified Expenses			
24-00799	2	Shipping	7.00	4-01- -190-283	Budget		86 1
				Unclassified Expenses			
			<u>132.80</u>				
42112	08/08/24	ANIMALCO Animal Control Solutions					5875
24-00017	15	August animal control	1,677.00	4-01- -235-273	Budget		10 1
				Other Contracted Service			
42113	08/08/24	AOC ALLIED OIL, LLC					5875
24-00069	15	6/17 unleaded	3,499.37	4-01- -283-751	Budget		35 1
				Motor Fuels			
24-00069	16	6/21 unleaded	258.70	4-01- -283-751	Budget		36 1
				Motor Fuels			

Check #	Check Date	Vendor	Amount Paid	Charge Account	Account Type	Reconciled/Void Contract	Ref Num	Ref Seq	Num Acct
CURRENT FUND		Investors Bank Current Fund		Continued					
42113	ALLIED OIL, LLC	Continued							
24-00069	17	6/28 unleaded	2,109.29	4-01- -283-751 Motor Fuels	Budget		37	1	
24-00069	18	7/12 unleaded	2,864.96	4-01- -283-751 Motor Fuels	Budget		38	1	
24-00069	19	7/26 unleaded	3,125.65	4-01- -283-751 Motor Fuels	Budget		39	1	
			<u>11,857.97</u>						
42114	08/08/24	APSCO AMERICAN PAPER & SUPPLY CO.					5875		
24-00084	4	2024 DPW JANITORIAL SUPPLIES	642.71	4-01- -205-254 Other Materials & Supplies	Budget		41	1	
42115	08/08/24	ASCARANO Angelo Scarano Inc.					5875		
24-00795	1	Portable Toilet	125.00	4-01- -245-265 Misc. Rental Costs	Budget		84	1	
42116	08/08/24	ATLAN ATLANTIC TACTICAL					5875		
24-00568	1	Defense Tech Rubber Balls	19.11	4-01- -190-276 Training Aids & Program	Budget		68	1	
24-00568	2	Winchester Ranger 12Guage Case	185.64	4-01- -190-276 Training Aids & Program	Budget		69	1	
			<u>204.75</u>						
42117	08/08/24	BATEM DIFRANCESCO, BATEMAN, COLEY,					5875		
24-00023	46	june legal tax appeals	5,040.00	4-01- -145-279 Prof. & Cons. Serv. Legal	Budget		12	1	
24-00023	49	Bonnie Burn Road	210.00	4-01- -145-279 Prof. & Cons. Serv. Legal	Budget		13	1	
24-00023	50	June legal	7,945.00	4-01- -145-279 Prof. & Cons. Serv. Legal	Budget		14	1	
24-00023	51	capodagi/meridia	70.00	4-01- -145-279 Prof. & Cons. Serv. Legal	Budget		15	1	
24-00023	52	S/K Morris Township Assoc	350.00	4-01- -145-279 Prof. & Cons. Serv. Legal	Budget		16	1	
			<u>13,615.00</u>						
42118	08/08/24	BATTERIE BATTERIES PLUS BULBS					5875		
24-00082	1	2024 DPW BATTERY SUPPLIES	44.87	4-01- -155-237 Bldg. Supplies & Materials	Budget		40	1	
42119	08/08/24	BRIGHTVI Bright View Engineering, LLC					5875		
24-00831	1	June meeting	525.00	4-01- -165-281 Prof. & Cons. Servs. Other	Budget		91	1	
42120	08/08/24	BUROJOES JOSEPH BURO					5875		
24-00865	1	RUTGERS PESTICIDE CORE EXAM	135.00	4-01- -155-276 Training Aids & Programs	Budget		116	1	
42121	08/08/24	CATHE005 Catherine Furlan					5875		
24-00861	1	Notary Supplies	104.22	4-01- -160-227 Office Supplies & Materials	Budget		112	1	

Check #	Check Date	Vendor	Amount Paid	Charge Account	Account Type	Reconciled/Void Contract	Ref Num
PO #	Item	Description					Ref Seq Acct
CURRENT FUND Investors Bank Current Fund Continued							
42122	08/08/24	CLIFF CLIFFSIDE BODY CORP.					5875
24-00190	1	2024 DPW TRUCK SERVICES	41.63	4-01- -205-247	Budget		58 1
				Vehicular Parts & Accessories			
42123	08/08/24	CUSUMANO Cusumano Perma-Rail					5875
24-00884	1	Texier House railing	1,400.00	4-01- -610-202	Budget		125 1
				Buildings & Grounds Improvements			
42124	08/08/24	DEER ReadyRefresh by Nestle					5875
24-00093	7	PD Drinking water Delivery	561.93	4-01- -190-283	Budget		42 1
				Unclassified Expenses			
42125	08/08/24	DSP DEBLYN SCREEN PRINTERS					5875
24-00873	1	Historical tee shirts	612.00	4-01- -280-232	Budget		121 1
				General Supplies			
42126	08/08/24	EAI EDMUNDS & ASSOCIATES, INC.					5875
24-00054	3	tax bill printing	643.80	4-01- -140-258	Budget		32 1
				Printing & Binding			
42127	08/08/24	ECAS 22 Auto Spa LLC					5875
24-00836	1	PD Car Washes May & June 2024	328.35	4-01- -190-269	Budget		93 1
				Vehicle Repair & Maint.			
24-00836	2	Boro Car Washes May/June 2024	89.55	4-01- -190-269	Budget		94 1
				Vehicle Repair & Maint.			
			417.90				
42128	08/08/24	EDF EDF Energy Services LLC					5875
24-00785	1	July Payment	1,366.44	4-01- -283-362	Budget		83 1
				Heating/AC			
42129	08/08/24	ELCORONA EL CORONADO					5875
24-00830	1	fire convention	7,864.00	4-01- -185-276	Budget		90 1
				Training Aids & Programs			
42130	08/08/24	ESIE ESI EQUIPMENT, INC.					5875
24-00841	1	ANNUAL SERVICE AGREEMENT	1,890.00	4-01- -185-233	Budget		98 1
				Computer Expenses			
42131	08/08/24	ESOSULUT ESO SOLUTIONS, INC.					5875
24-00774	1	FIRE PACKAGE & CAD INTEGRATION	2,566.80	4-01- -185-231	Budget		81 1
				Emergency & Safety Supplies			
42132	08/08/24	EVOQUA EVOQUA WATER TECHNOLOGIES, LLC					5875
24-00105	7	2024 DPW MATERIAL & SUPPLIES	2,575.80	4-01- -225-254	Budget		43 1
				Other Material & Supplies			
42133	08/08/24	FEDEX FEDEX					5875
24-00029	20	mailing	258.50	4-01- -160-281	Budget		19 1
				Prof. & Cons. Servs. Other			

Check #	Check Date	Vendor	Amount Paid	Charge Account	Account Type	Reconciled/Void Contract	Ref Num
PO #	Item	Description					Ref Seq Acct
CURRENT FUND		Investors Bank Current Fund		Continued			
42134	08/08/24	FINNE FINNE BUILDING & INVESTMENT					5875
24-00672	1	1020 Johnston Dr drainage	10,350.00	4-01- -610-201 Infrastructure Improvements	Budget		71 1
42135	08/08/24	FITRITEU FIT-RITE UNIFORM CO., INC.					5875
23-01303	1	UNIFORM - TOM MCNULTY	344.47	3-01- -187-239 Uniforms, Clothing Expense	Budget		3 1
42136	08/08/24	FLEM FLEMINGTON DEPARTMENT STORE					5875
24-00369	1	2024 DPW CLOTHING ALLOWANCE	3,713.84	4-01- -205-239 Uniforms, Clothing Expense	Budget		61 1
42137	08/08/24	FORT SUN LIFE FINANCIAL					5875
24-00872	1	August payment	285.50	4-01- -175-394 Life Insurance	Budget		120 1
42138	08/08/24	GENEVIEV GENEVIEVE NITZSCHE					5875
24-00842	1	AHA BLS PROVIDER CPR COURSE	282.00	4-01- -185-276 Training Aids & Programs	Budget		99 1
42139	08/08/24	GFG GRAY'S FLORIST & GREENHOUSE					5875
24-00559	1	Community Picnic - decorations	270.00	4-01- -245-201 Community Picnic	Budget		65 1
24-00559	2	Memorial Day - Red/White/Blue	200.00	4-01- -110-278 Community Relations	Budget		66 1
24-00559	3	Memorial Day - Wreath	250.00	4-01- -110-278 Community Relations	Budget		67 1
			720.00				
42140	08/08/24	GLS GROVE LOCK & SAFE CO.					5875
24-00111	2	2024 DPW REPAIR/MAINTENANCE	424.50	4-01- -155-273 Bldg.-Other Contracted Serv.	Budget		44 1
42141	08/08/24	GREAT Great America Financial Serv.					5875
24-00037	11	folder / stuffer	718.00	4-01- -130-281 Prof. & Contr. Services-Other	Budget		27 1
42142	08/08/24	HANCE WILLIAM HANCE					5875
24-00007	19	Rackspace 7/18 & 8/18	1,914.00	4-01- -115-233 Computer Expenses	Budget		9 1
42143	08/08/24	HANNON Hannon Floors					5875
24-00393	1	Heavy Duty Triumph RubberFloor	3,885.75	4-01- -610-202 Buildings & Grounds Improvements	Budget		62 1
42144	08/08/24	HODE2 HOME DEPOT CREDIT SERVICES					5875
24-00120	7	2024 DPW PURCHASES	1,132.99	4-01- -205-244 Hardware and Minor Tools	Budget		45 1
42145	08/08/24	HOMED HOME DEPOT CREDIT SERVICES					5875
24-00121	5	2024 FIRE DEPT. PURCHASES	619.13	4-01- -185-246 Equip. & Machinery Parts	Budget		46 1

Check #	Check Date	Vendor	Amount Paid	Charge Account	Account Type	Reconciled/Void Contract	Ref Num
PO #	Item	Description					Seq Acct
CURRENT FUND Investors Bank Current Fund Continued							
42146	08/08/24	INTERGLO Interglobe Communications					5875
24-00782	2	Phone service August	1,238.29	4-01- -283-459 Telephone	Budget		82 1
42147	08/08/24	JSSP JOHNSTONE SUPPLY- S.PLAINFIELD					5875
24-00124	4	2024 DPW PURCHASES/SUPPLIES	1,449.00	4-01- -155-284 HVAC Repairs	Budget		47 1
42148	08/08/24	KNOX KNOX COMPANY					5875
24-00732	1	1YR KNOXCONNECT CLOUD LICENSE	584.00	4-01- -185-281 Prof & Contr. Services-Other	Budget		74 1
42149	08/08/24	LACA RONALD LACAILLADE					5875
24-00720	2	Medicare Part B Reimbursement	1,397.60	4-01- -175-393 Health Benefits Plan	Budget		72 1
42150	08/08/24	LANGU LANGUAGE LINE SERVICES					5875
24-00325	2	court interpreter	76.50	4-01- -405-282 Specialized Services	Budget		60 1
42151	08/08/24	LINNU FRANCIS P LINNUS ESQ					5875
24-00846	1	General PB July	64.75	4-01- -160-281 Prof. & Cons. Servs. Other	Budget		102 1
24-00854	1	General Meeting July	1,250.00	4-01- -160-281 Prof. & Cons. Servs. Other	Budget		108 1
24-00855	1	BB Litigation	259.00	4-01- -185-281 Prof & Contr. Services-Other	Budget		109 1
			<u>1,573.75</u>				
42152	08/08/24	LSC2 LIBERTY SCIENCE CENTER					5875
24-00848	1	Rainy Day Trip	1,056.00	4-01- -245-202 Summer Camp	Budget		104 1
42153	08/08/24	LUBECK Bradley Lubeck					5875
24-00888	1	tax overpayment refund	5,486.84	4-01- -921-999 REFUND TAX OVERPAYMENT	Budget		130 1
42154	08/08/24	MARMIC Marmic Associates					5875
24-00004	22	July proactive	990.00	4-01- -115-233 Computer Expenses	Budget		6 1
24-00004	23	July backup	200.00	4-01- -115-233 Computer Expenses	Budget		7 1
24-00004	24	July services	1,062.50	4-01- -115-233 Computer Expenses	Budget		8 1
			<u>2,252.50</u>				
42155	08/08/24	MCANJ MCANJ Treasurer					5875
24-00843	1	MCANJ GIL & LANGE	175.00	4-01- -120-256 Membership Dues	Budget		100 1

Check #	Check Date	Vendor	Amount Paid	Charge Account	Account Type	Reconciled/Void Contract	Ref Seq	Ref Num
PO #	Item	Description						Acct
CURRENT FUND		Investors Bank Current Fund		Continued				5875
42156	08/08/24	MGL MGL PRINTING SOLUTIONS						113 1
24-00862	1	SHIPPING FEES	29.00	4-01- -120-258 Printing & Binding	Budget			
42157	08/08/24	MPI WOODS MACHINERY						5875
24-00166	3	2024 DPW SUPPLIES	690.27	4-01- -205-254 Other Materials & Supplies	Budget			56 1
42158	08/08/24	NJAPZ NJAPZA						5875
24-00863	1	Member Dues	100.00	4-01- -160-256 Membership Dues	Budget			114 1
42159	08/08/24	NJFE NJ FIRE EQUIPMENT CO.						5875
24-00181	10	2024 SAFETY SUPPLIES	870.36	4-01- -185-231 Emergency & Safety Supplies	Budget			57 1
42160	08/08/24	NJHMG005 New Jersey Hills Media Group						5875
24-00758	1	Legal Ads	99.65	4-01- -120-255 Advertising Costs	Budget			76 1
24-00758	2	Legal Ads	16.32	4-01- -120-255 Advertising Costs	Budget			77 1
24-00758	3	Legal Ads	22.44	4-01- -120-255 Advertising Costs	Budget			78 1
24-00758	4	Legal Ads	20.40	4-01- -120-255 Advertising Costs	Budget			79 1
24-00844	1	BA24R10; Eghelshi	27.54	4-01- -165-255 Advertising & Promotional	Budget			101 1
			186.35					
42161	08/08/24	NJLM NJ LEAGUE OF MUNICIPALITIES						5875
24-00826	1	8/28/24 Registration	90.00	4-01- -120-276 Training Aids & Programs	Budget			89 1
42162	08/08/24	NORTHERN NORTHERN NURSERIES, INC.						5875
24-00137	4	2024 DPW - PLANTS, TREES & ETC	3,196.56	4-01- -155-254 Other Materials & Supplies	Budget			48 1
42163	08/08/24	ON-SI ON-SITE FLEET SERVICE						5875
24-00546	2	2024 DPW TRUCK REPAIRS	1,566.52	4-01- -205-269 Vehicle Repairs & Maintenance	Budget			64 1
42164	08/08/24	PACIFICL PACIFIC LAWN SPRINKLERS						5875
24-00138	1	2024 SPRINKLER REPAIRS	4,332.00	4-01- -155-266 Building Repair & Maintenance	Budget			49 1
42165	08/08/24	PINTO PINTO BROTHERS						5875
24-00139	5	2024 8-YD ROLL-OFF CONTAINER	728.50	4-01- -155-273 Bldg.-Other Contracted Serv.	Budget			50 1
42166	08/08/24	RCFORGS RUTGERS CENTER FOR GOV. SERVIC						5875
24-00847	1	PZ-3301; PZ3302	780.00	4-01- -160-276 Training Aids & Program	Budget			103 1

Check #	Check Date	Vendor	Amount Paid	Charge Account	Account Type	Reconciled/Void Contract	Ref Num	Ref Seq	Acct
CURRENT FUND		Investors Bank Current Fund		Continued					
42167	08/08/24	REMINGTO Remington & Vernick Engineers					5875		
23-00557	17	2023 Roadway Improvements	3,067.40	3-01- -610-201	Budget		1	1	
				Infrastructure Improvements					
23-00557	18	2023 Roadway Improvements	7,882.37	3-01- -610-201	Budget		2	1	
				Infrastructure Improvements					
24-00201	7	Stormwater outfall mapping	2,383.00	3-01- -610-201	Budget		59	1	
				Infrastructure Improvements					
24-00874	2	July engineering	2,124.24	3-01- -610-201	Budget		122	1	
				Infrastructure Improvements					
24-00874	3	July engineering	20,529.18	4-01- -610-201	Budget		123	1	
				Infrastructure Improvements					
			<u>35,986.19</u>						
42168	08/08/24	RG Ruderman & Roth LLC					5875		
24-00021	3	Labor attorney services	297.00	3-01- -145-211	Budget		11	1	
				Labor Attorney					
42169	08/08/24	RT23AUTO ROUTE 23 AUTO MALL					5875		
24-00149	2	2024 DPW SERVICE/REPAIRS	600.00	4-01- -205-247	Budget		51	1	
				Vehicular Parts & Accessories					
42170	08/08/24	RUT RUTGERS UNIVERSITY					5875		
24-00801	1	Municipal Tax Collection 2	1,129.00	4-01- -140-276	Budget		87	1	
				Training Aids & Programs					
24-00849	1	MANAGEMENT TASKS	944.00	4-01- -205-276	Budget		105	1	
				Training Aids & Programs					
24-00849	2	MANAGING & DEVELOPING	760.00	4-01- -205-276	Budget		106	1	
				Training Aids & Programs					
24-00849	3	PUBLIC RELATIONS	575.00	4-01- -205-276	Budget		107	1	
				Training Aids & Programs					
24-00860	1	LANGE REG. FOR ADVANCED DUTIES	653.00	4-01- -120-276	Budget		111	1	
				Training Aids & Programs					
24-00864	1	LANGE REG. FOR ELECTIONS ADMIN	653.00	4-01- -120-276	Budget		115	1	
				Training Aids & Programs					
24-00866	1	MANAGEMENT TASKS	944.00	4-01- -205-276	Budget		117	1	
				Training Aids & Programs					
24-00866	2	MANAGING & DEVELOPING	760.00	4-01- -205-276	Budget		118	1	
				Training Aids & Programs					
24-00866	3	PUBLIC RELATIONS	575.00	4-01- -205-276	Budget		119	1	
				Training Aids & Programs					
			<u>6,993.00</u>						
42171	08/08/24	SAVOSCHA Savo, Schaik, Corsini, warner					5875		
24-00834	1	May General BA	148.00	4-01- -165-281	Budget		92	1	
				Prof. & Cons. Servs. Other					
24-00838	1	BA Eghelshi	499.50	4-01- -185-281	Budget		95	1	
				Prof & Contr. Services-Other					
24-00839	1	Carty E-BA24-01	1,239.50	4-01- -165-281	Budget		96	1	
				Prof. & Cons. Servs. Other					
			<u>1,887.00</u>						

Check #	Check Date	Vendor	Amount Paid	Charge Account	Account Type	Reconciled/Void Contract	Ref Num
PO #	Item	Description					Ref Seq Acct
CURRENT FUND Investors Bank Current Fund Continued							
42172	08/08/24	SHT Somerset Hills Towing					5875
24-00506	1	Tow Car 10 to WSC (Flat Tire)	43.50	4-01- -190-269 Vehicle Repair & Maint.	Budget		63 1
42173	08/08/24	SOM09 SOMERSET COUNTY ROAD DIVISION					5875
24-00156	4	3rd qtr recycling	15,511.50	4-01- -465-283 Unclassified Expenses	Budget		52 1
42174	08/08/24	SOM10 SOMERSET C'TY TAXES					5875
24-00044	3	3rd qtr county taxes	1,568,830.96	4-01- -907-999 COUNTY TAXES PAYABLE	Budget		29 1
42175	08/08/24	SOM13 SOMERSET C'TY LIBRARY TAX					5875
24-00045	3	county library taxes 3rd qtr	212,569.42	4-01- -908-999 COUNTY LIBRARY TAXES PAYABLE	Budget		30 1
42176	08/08/24	SOM14 SOMERSET C'TY OPEN SPACE TAX					5875
24-00046	3	county open space tax 3rd qtr	169,143.40	4-01- -909-999 COUNTY OPEN SPACE TAX PAYABLE	Budget		31 1
42177	08/08/24	SPSCO SOMERSET PLUMBING SUPPLY CO.					5875
24-00157	5	2024 DPW MATERIALS/SUPPLIES	798.96	4-01- -155-237 Bldg. Supplies & Materials	Budget		53 1
42178	08/08/24	STAPL STAPLES BUSINESS ADVANTAGE					5875
24-00637	9	office supplies	286.91	4-01- -130-227 Office Supplies & Materials	Budget		70 1
24-00881	1	coffee supplies	148.02	4-01- -110-235 Food & Drugs	Budget		124 1
			434.93				
42179	08/08/24	THESIGN The Sign Center					5875
24-00766	1	Lettering Car 16	750.00	4-01- -190-223 Vehicular Equipment (Cars)	Budget		80 1
24-00821	1	Letter Car 13	750.00	4-01- -190-223 Vehicular Equipment (Cars)	Budget		88 1
			1,500.00				
42180	08/08/24	TOSHI TOSHIBA BUSINESS SOLUTIONS					5875
24-00033	28	Xmedius Cloud	44.84	4-01- -283-459 Telephone	Budget		26 1
42181	08/08/24	TOSHIBA Toshiba Financial Services					5875
24-00031	37	copier lease	1,448.74	4-01- -120-228 Photocopy Expense	Budget		20 1
24-00031	38	copier lease	3,318.76	4-01- -120-228 Photocopy Expense	Budget		21 1
24-00031	39	copier lease	999.55	4-01- -190-228 Photocopy Expense	Budget		22 1

Check #	Check Date	Vendor	Amount Paid	Charge Account	Account Type	Reconciled/Void Contract	Ref Num
PO #	Item	Description					Ref Seq Acct
CURRENT FUND		Investors Bank Current Fund	Continued				
42181	Toshiba	Financial Services	Continued				
24-00031	40	copier lease	140.00	4-01- -120-228	Budget		23 1
			<u>5,907.05</u>	Photocopy Expense			
42182	08/08/24	TTSI TIMETRACK SYSTEMS INC.					5875
24-00039	8	time clock service	114.75	4-01- -130-281	Budget		28 1
				Prof. & Contr. Services-Other			
42183	08/08/24	WAC WELDON ASPHALT COMPANY					5875
24-00164	4	2024 DPW ASPHALT MATERIAL	469.41	4-01- -205-242	Budget		55 1
				Asphalt, Paving Materials			
42184	08/08/24	WAI WITMER PUBLIC SAFETY GROUP					5875
24-00840	1	SEEK FIREPRO 300, FAST FRAME	1,512.61	4-01- -185-248	Budget		97 1
				Communications Equip. Parts			
24-00859	1	SAW BLADES	270.78	4-01- -185-246	Budget		110 1
			<u>1,783.39</u>	Equip. & Machinery Parts			
42185	08/08/24	WAR01 Costello's Ace Hardward					5875
24-00161	7	2024 DPW MATERIALS/SUPPLIES	1,120.41	4-01- -155-232	Budget		54 1
				General Supplies			
42186	08/08/24	WAT04 WATCHUNG BOROUGH GRANT FUND					5875
24-00887	1	Safe & Secure Local Share 2024	210,000.00	4-01- -510-202	Budget		129 1
				Local Share Expenses			
42187	08/08/24	WAT05 WATCHUNG BOROUGH CAPITAL ACCT.					5875
24-00886	1	2024 budget deferred charges	152,855.22	4-01- -720-203	Budget		128 1
				Deferred Charges			
42188	08/08/24	WAT8 WATCHUNG RESCUE SQUAD					5875
24-00885	1	2024 budget funding	35,416.00	4-01- -195-283	Budget		126 1
				Unclassified Expenses			
24-00885	2	2024 budget funding	24,000.00	4-01- -610-208	Budget		127 1
			<u>59,416.00</u>	Rescue Squad Equipment			
42189	08/08/24	WBB0E WATCHUNG BOROUGH BOARD OF ED					5875
24-00001	9	school taxes September	1,517,415.00	4-01- -901-999	Budget		4 1
				WAT BD OF ED TAXES PAYABLE			
42190	08/08/24	WBMASON W.B Mason, Co Inc.					5875
24-00723	1	BATTERIES	40.94	4-01- -120-227	Budget		73 1
				Office Supplies & Materials			
24-00752	1	OFFICE SUPPLIES	47.57	4-01- -120-227	Budget		75 1
			<u>88.51</u>	Office Supplies & Materials			

Check #	Check Date	Vendor	Amount Paid	Charge Account	Account Type	Reconciled/Void Contract	Ref Num Ref Seq Acct																																
CURRENT FUND Investors Bank Current Fund Continued																																							
42191	08/08/24	WHRHS WATCHUNG HILLS REG.HIGH SCHOOL					5875																																
24-00002	9	school taxes September	671,896.00	4-01- -902-999 WHRHS TAXES PAYABLE	Budget		5 1																																
<table border="0"> <tr> <td>Checking Account Totals</td> <td></td> <td><u>Paid</u></td> <td><u>Void</u></td> <td><u>Amount Paid</u></td> <td><u>Amount Void</u></td> <td></td> <td></td> </tr> <tr> <td>Checks:</td> <td>104</td> <td>0</td> <td>0</td> <td>7,152,470.36</td> <td>0.00</td> <td></td> <td></td> </tr> <tr> <td>Direct Deposit:</td> <td>0</td> <td>0</td> <td>0</td> <td>0.00</td> <td>0.00</td> <td></td> <td></td> </tr> <tr> <td>Total:</td> <td>104</td> <td>0</td> <td>0</td> <td>7,152,470.36</td> <td>0.00</td> <td></td> <td></td> </tr> </table>								Checking Account Totals		<u>Paid</u>	<u>Void</u>	<u>Amount Paid</u>	<u>Amount Void</u>			Checks:	104	0	0	7,152,470.36	0.00			Direct Deposit:	0	0	0	0.00	0.00			Total:	104	0	0	7,152,470.36	0.00		
Checking Account Totals		<u>Paid</u>	<u>Void</u>	<u>Amount Paid</u>	<u>Amount Void</u>																																		
Checks:	104	0	0	7,152,470.36	0.00																																		
Direct Deposit:	0	0	0	0.00	0.00																																		
Total:	104	0	0	7,152,470.36	0.00																																		
GRANT FUND Investors Savings Grant Fund																																							
3127	08/08/24	BARCOPRO BARCO PRODUCTS					5876																																
24-00433	1	KRC1744-CD/GN - 90GAL CONTAIN	4,797.70	G-03- -520-119 Clean Communities Grant 2022	Budget		1 1																																
24-00433	2	KRC1744-CD/GN - 90GAL CONTAIN	676.75	G-03- -520-119 Clean Communities Grant 2022	Budget		2 1																																
<table border="0"> <tr> <td></td> <td></td> <td></td> <td></td> <td>5,474.45</td> <td></td> <td></td> <td></td> </tr> </table>												5,474.45																											
				5,474.45																																			
<table border="0"> <tr> <td>Checking Account Totals</td> <td></td> <td><u>Paid</u></td> <td><u>Void</u></td> <td><u>Amount Paid</u></td> <td><u>Amount Void</u></td> <td></td> <td></td> </tr> <tr> <td>Checks:</td> <td>1</td> <td>0</td> <td>0</td> <td>5,474.45</td> <td>0.00</td> <td></td> <td></td> </tr> <tr> <td>Direct Deposit:</td> <td>0</td> <td>0</td> <td>0</td> <td>0.00</td> <td>0.00</td> <td></td> <td></td> </tr> <tr> <td>Total:</td> <td>1</td> <td>0</td> <td>0</td> <td>5,474.45</td> <td>0.00</td> <td></td> <td></td> </tr> </table>								Checking Account Totals		<u>Paid</u>	<u>Void</u>	<u>Amount Paid</u>	<u>Amount Void</u>			Checks:	1	0	0	5,474.45	0.00			Direct Deposit:	0	0	0	0.00	0.00			Total:	1	0	0	5,474.45	0.00		
Checking Account Totals		<u>Paid</u>	<u>Void</u>	<u>Amount Paid</u>	<u>Amount Void</u>																																		
Checks:	1	0	0	5,474.45	0.00																																		
Direct Deposit:	0	0	0	0.00	0.00																																		
Total:	1	0	0	5,474.45	0.00																																		
PNC DEV ESCROW Investors Developer Escrow																																							
15624	08/08/24	BATEM DIFRANCESCO, BATEMAN, COLEY,					5877																																
24-00023	48	BJS development compliance	87.50	E-E24-094 Bjs wholesale	Project		1 1																																
15625 08/08/24 LINNU FRANCIS P LINNUS ESQ																																							
24-00851	1	BB Amended site plans	296.00	E-PB24-01 Bonnie Burn Rd PB19-01	Project		3 1																																
24-00852	1	BB Ameded application	1,017.50	E-PB24-01 Bonnie Burn Rd PB19-01	Project		4 1																																
24-00853	1	BB Amended site plans	675.25	E-PB24-01 Bonnie Burn Rd PB19-01	Project		5 1																																
24-00856	1	Retaining Wall	9.25	E-PB22-01 1701 Rt 22 Shop Rite	Project		6 1																																
<table border="0"> <tr> <td></td> <td></td> <td></td> <td></td> <td>1,998.00</td> <td></td> <td></td> <td></td> </tr> </table>												1,998.00																											
				1,998.00																																			
15626 08/08/24 REMINGTO Remington & Vernick Engineers																																							
24-00875	4	Starbucks	130.13	E-E20-156 1662 US Route 22 Urgent Care	Project		9 1																																
24-00875	5	Starbucks	5,536.60	E-SERITAG1 1640 US Route 22-Theater Const	Project		10 1																																
24-00875	6	July Engineering	150.00	E-E06-56 91 Tuttle Road	Project		11 1																																
24-00875	7	July Engineering	150.00	E-E20-079 36 Valley View Road E20-079	Project		12 1																																
24-00875	8	July Engineering	400.00	E-E24-094 Bjs wholesale	Project		13 1																																
24-00875	9	July Engineering	200.00	E-E24-0009 39 High Oaks Drive 24-00009	Project		14 1																																

Check #	Check Date	Vendor	Amount Paid	Charge Account	Account Type	Reconciled/Void Contract	Ref Num	Ref Seq	Acct
PNC DEV ESCROW Investors Developer Escrow Continued									
15626	Remington & Vernick Engineers	Continued							
24-00875	10	July Engineering	150.00	E-E24-094	Project		15	1	
				BJs wholesale					
24-00875	11	July Engineering	100.00	E-E22-0272	Project		16	1	
				25 Price Drive 22-00272					
24-00875	12	July Engineering	100.00	E-E24-0009	Project		17	1	
				39 High Oaks Drive 24-00009					
24-00875	13	July Engineering	100.00	E-E20-079	Project		18	1	
				36 valley View Road E20-079					
24-00875	14	July Engineering	100.00	E-E22-0272	Project		19	1	
				25 Price Drive 22-00272					
24-00875	15	July Engineering	100.00	E-SERITAG1	Project		20	1	
				1640 US Route 22-Theater Const					
24-00875	16	July Engineering	100.00	E-E20-079	Project		21	1	
				36 valley View Road E20-079					
24-00875	17	July Engineering	42.13	E-E16-012	Project		22	1	
				105 Washington Rock Road					
24-00875	18	July Engineering	75.00	E-E20-079	Project		23	1	
				36 Valley View Road E20-079					
24-00875	19	July Engineering	132.87	E-SERITAG1	Project		24	1	
				1640 US Route 22-Theater Const					
24-00875	20	July Engineering	200.00	E-E22-0078	Project		25	1	
				448 Johnston Drive GCP22-0078					
			7,766.73						
15627	08/08/24	SAVOSCHA Savo, Schalk, Corsini, Warner					5877		
24-00835	1	May 15th Carvajal	37.00	E-BA24-03	Project		2	1	
				10 Watchung Crest Drive					
15628	08/08/24	STIRE DAVID STIRES ASSOC LLC					5877		
24-00857	1	Woo-GoChan	212.00	E-BA24-04	Project		7	1	
				74 Lakeview Ave BA24-04					
24-00858	1	BJ's Compliance	467.50	E-BA23-02	Project		8	1	
				1601 US Hwy 22 BJs Wholesale					
			679.50						
Checking Account Totals			<u>Paid</u>	<u>Void</u>	<u>Amount Paid</u>	<u>Amount Void</u>			
		Checks:	5	0	10,568.73	0.00			
		Direct Deposit:	0	0	0.00	0.00			
		Total:	5	0	10,568.73	0.00			
PNC OTHER ESC Investors Savings Other Escrow									
169	07/30/24	WATCHUNG BORO. PAYROLL ACCT.				(Replacement of: PNC OTHER ESC 15465)	5866		
24-00643	28	Watchung Boro Payroll	30,981.63	T-93- -100-208	Budget		4	1	
				Accumulated Sick Leave					
24-00807	1	Watchung Boro PD Payroll	18,445.00	T-93- -100-5ED	Budget		6	1	
				Extra Duty Solutions Funds					
			49,426.63						
170	07/31/24	WATCHUNG BORO. PAYROLL ACCT.					5871		
24-00828	1	Watchung Boro PD Payroll	17,577.42	T-93- -100-5ED	Budget		1	1	
				Extra Duty Solutions Funds					

Check #	Check Date	Vendor	Amount Paid	Charge Account	Account Type	Reconciled/Void Contract	Ref Num
PO #	Item	Description					Ref Seq Acct
PNC OTHER ESC Investors Savings Other Escrow Continued							
171	07/31/24	WAT01 WATCHUNG BORO. PAYROLL ACCT.					5871
24-00868	1	Watchung Boro PD Payroll	18,572.50	T-93- -100-5ED Extra Duty Solutions Funds	Budget		2 1
24-00868	2	Watchung Boro PD Payroll	1,417.50	T-93- -100-502 Levin Management (Blue Star)	Budget		3 1
			<u>19,990.00</u>				
15467 08/08/24 REEFECO Reefco Aquarium Service, LLC							
24-00035	7	Library aquarium	100.00	T-93- -100-110 Watchung Public Library Advisory Board	Budget		5878 1 1
15468 08/08/24 REMINGTO Remington & Vernick Engineers							
24-00875	2	Ness property	340.00	T-93- -100-213 Ness Property Cleanup	Budget		5878 5 1
24-00875	3	Ness property	550.00	T-93- -100-213 Ness Property Cleanup	Budget		6 1
			<u>890.00</u>				
15469 08/08/24 WAT03 WATCHUNG BOROUGH CURRENT FUND							
24-00829	1	Watchung Boro Admin Fees	4,389.00	T-93- -100-5ED Extra Duty Solutions Funds	Budget		5879 2 1
24-00869	1	Watchung Boro Admin Fees	4,807.00	T-93- -100-5ED Extra Duty Solutions Funds	Budget		3 1
24-00869	2	Watchung Boro Admin Fees	299.25	T-93- -100-502 Levin Management (Blue Star)	Budget		4 1
			<u>9,495.25</u>				
Checking Account Totals							
			<u>Paid</u>	<u>Void</u>	<u>Amount Paid</u>	<u>Amount Void</u>	
		Checks:	6	0	97,479.30	0.00	
		Direct Deposit:	0	0	0.00	0.00	
		Total:	<u>6</u>	<u>0</u>	<u>97,479.30</u>	<u>0.00</u>	
Report Totals							
			<u>Paid</u>	<u>Void</u>	<u>Amount Paid</u>	<u>Amount Void</u>	
		Checks:	123	0	7,414,620.57	0.00	
		Direct Deposit:	0	0	0.00	0.00	
		Total:	<u>123</u>	<u>0</u>	<u>7,414,620.57</u>	<u>0.00</u>	

Totals by Year-Fund Fund Description	Fund	Budget Total	Revenue Total	G/L Total	Total
Current Fund	3-01	16,098.48	0.00	0.00	16,098.48
Current Fund	4-01	7,136,371.88	0.00	0.00	7,136,371.88
	A-04	7,750.05	0.00	0.00	7,750.05
Capital Fund	C-02	139,558.88	0.00	0.00	139,558.88
	D-11	7.80	0.00	0.00	7.80
Grant Fund	G-03	5,474.45	0.00	0.00	5,474.45
	H-06	1,311.00	0.00	0.00	1,311.00
	T-93	97,479.30	0.00	0.00	97,479.30
Total of All Funds:		<u>7,404,051.84</u>	<u>0.00</u>	<u>0.00</u>	<u>7,404,051.84</u>

DRAFT

Project Description	Project No.	Project Total
1601 US Hwy 22 BJs Wholesale	E-BA23-02	467.50
10 Watchung Crest Drive	E-BA24-03	37.00
74 Lakeview Ave BA24-04	E-BA24-04	212.00
91 Tuttle Road	E-E06-56	150.00
105 Washington Rock Road	E-E16-012	42.13
36 Valley View Road E20-079	E-E20-079	425.00
1662 US Route 22 Urgent Care	E-E20-156	130.13
448 Johnston Drive GCP22-0078	E-E22-0078	200.00
25 Price Drive 22-00272	E-E22-0272	200.00
39 High Oaks Drive 24-00009	E-E24-0009	300.00
BJs Wholesale	E-E24-094	637.50
1701 Rt 22 Shop Rite	E-PB22-01	9.25
Bonnie Burn Rd PB19-01	E-PB24-01	1,988.75
1640 US Route 22-Theater Const	E-SERITAG1	5,769.47
Total Of All Projects:		<u>10,568.73</u>

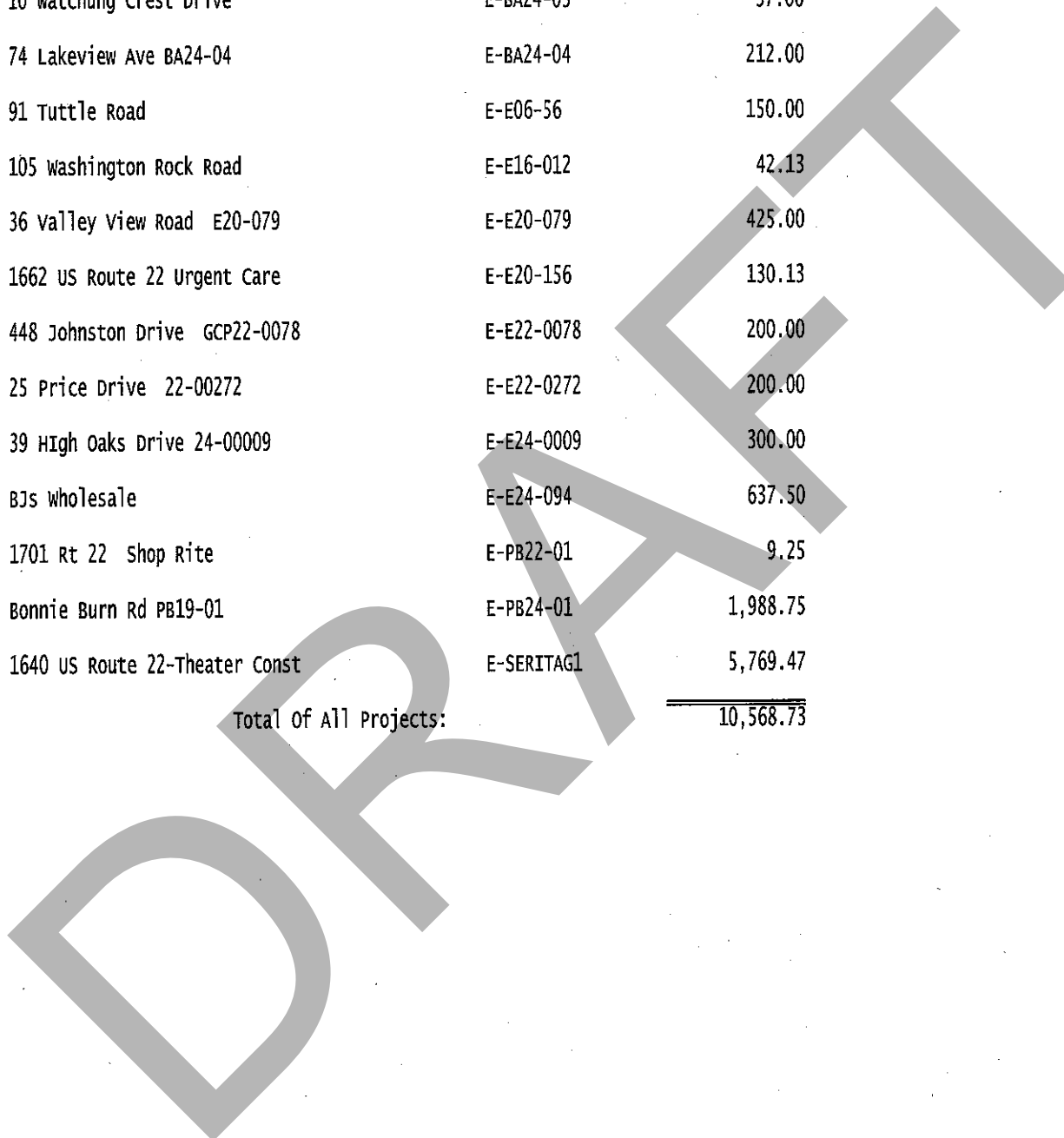

**BOROUGH OF WATCHUNG
RESOLUTION: R4**

WHEREAS, Applicant Asha Ricci applied for Week 4 of the Borough's Summer Camp program and her child became sick, which made her unable to attend and is now requesting a refund; and

WHEREAS, the Governing Body wishes to authorize and proceed with the return of the application fee.

NOW, THEREFORE, BE IT RESOLVED, by the Mayor and Council of the Borough of Watchung, County of Somerset, State of New Jersey that the Chief Financial Officer is hereby authorized to refund \$350.00 to Asha Ricci, 37 Pine Lane, Watchung, NJ 07069.

Christine B. Ead, Council President

Ronald Jubin, Ph.D., Mayor

ADOPTED: AUGUST 15, 2024
INDEX: MISC., RECREATION
C: B. HANCE, D.GRAY,

**BOROUGH OF WATCHUNG
RESOLUTION: R5**

*A RESOLUTION CONSENTING TO THE PROPOSED NORTHEAST, UPPER
RARITAN AND LOWER RARITAN/MIDDLESEX COUNTY WATER QUALITY
MANAGEMENT (WQM) PLAN AMENDMENT*

WHEREAS, the Borough of Watchung desires to provide for the orderly development of wastewater facilities within Watchung; and

WHEREAS, the New Jersey Department of Environmental Protection (NJDEP) requires that proposed wastewater treatment and conveyance facilities and wastewater treatment service areas, as well as related subjects, conform with an approved WQM plan; and

WHEREAS, the NJDEP has established the WQM plan amendment procedure through the WQMP rules at N.J.A.C. 7:15-3.5 as the method of incorporating unplanned facilities into a WQM plan; and

WHEREAS, a proposed WQM plan amendment publicly noticed in the New Jersey Register on June 17, 2024, for Somerset County Septic Management Plan, Somerset County [PI# 435442, Activity No. AMD200004; PI# 435434, Activity No.200007; PI# 435463, Activity No. AMD200001 has been prepared by the Somerset County Planning Board and submitted on behalf of the Somerset County Board of County Commissioners;

NOW, THEREFORE, BE IT RESOLVED on this 15th day of August 2024, by the governing body of the Borough of Watchung that:

1. The Mayor and Council hereby consents to the Somerset County Septic Management Plan amendment, publicly noticed in the New Jersey Register on June 17, 2024 by Somerset County, for the purpose of its incorporation into the applicable WQM plan(s).
2. This consent shall be submitted to the NJDEP pursuant to N.J.A.C. 7:15-3.5(g)6.

Christine B. Ead, Council President

Ronald Jubin, Ph.D., Mayor

ADOPTED: AUGUST 15, 2024
INDEX: MISC, SEWERS-SANITARY,
C: BOH, NJDEP, SC PLANNING BD,

I do hereby certify that the foregoing is a true copy of a Resolution passed by the Governing Body at a meeting duly held on August 15, 2024.

Edith G. Gil, RMC

**BOROUGH OF WATCHUNG
RESOLUTION: R6**

WHEREAS, the Borough will hold Movie Night on September 13, 2024 with a rain date of September 27th , and permission has been requested to include a small fireworks display; and

WHEREAS, the fireworks display will be sponsored by the Borough of Watchung; and

WHEREAS, the Borough's Recreation Coordinator seeks to waive the section of the Borough Code prohibiting the discharge of fireworks for this event, as set forth in Chapter 6-2.11 of the Code of the Borough of Watchung; and

WHEREAS, the Borough has on file a fireworks permit application with the Borough Fire Official and upon the Fire Official's recommendation the Mayor and Council hereby also authorize the waiver of the Firework Permit Fee of \$427.00.

NOW, THEREFORE, BE IT RESOLVED by the Mayor and Council of the Borough of Watchung that the prohibition of the discharge of fireworks is hereby waived along with applicable borough fees for the Borough's Movie Night celebration scheduled for September 13, 2024, with a rain date of September 27, 2024 at Phillips Field.

Christine B. Ead, Council President

Ronald Jubin, Ph.D., Mayor

ADOPTED: AUGUST 15, 2024
INDEX: MISC.
C: POLICE, FIRE OFFICIAL,
D.GRAY,

**BOROUGH OF WATCHUNG
RESOLUTION: R7**

WHEREAS, Mayor and Council previously adopted resolution R9 on July 18, 2024 authorizing a revocable license agreement with the current owner of the property located at Block 43.04, Lot 17.11 in the Borough of Watchung, County of Somerset, State of New Jersey, located at 23 Blue Wolf Trail (the “Property”); and

WHEREAS, the prior resolution incorrectly listed the name of the property owner and this resolution seeks to correct the record; and

WHEREAS, Amit H. Patel, is the correct current owner of the property located at Block 43.04, Lot 17.11 in the Borough of Watchung, County of Somerset, State of New Jersey, located at 23 Blue Wolf Trail (the “Property”); and

WHEREAS, the Borough has an existing 20’ Wide Sanitary Sewer Easement traversing a portion of the Property (the “Easement”); and

WHEREAS, Amit H. Patel, requested a revocable license from the Borough to allow for the construction and location of a proposed fence across the Borough’s Easement at two (2) locations on the Property; and

WHEREAS, the Borough Engineer has reviewed Mr. Patel’s request and recommends that the Borough authorize this request conditioned upon the full execution of a Revocable License; and

WHEREAS, the Borough and Amit H. Patel, negotiated and agreed upon a Revocable License, which shall be recorded with the Somerset County Clerk’s Office, be binding on all successors of title to the Property, and run with the land; and

WHEREAS, the Borough finds it reasonable and appropriate to grant this Revocable License to Amit H. Patel, to allow for the location of the proposed fence across and within the Borough’s Easement on the Property.

NOW, THEREFORE, BE IT RESOLVED by the Borough Council of the Borough of Watchung, County of Somerset, State of New Jersey, that the Borough hereby authorizes the granting of the Revocable License to Amit H. Patel, to allow for the location of the proposed fence across and within the Borough’s Easement on the Property.

BE IT FURTHER RESOLVED that the Mayor and Borough Clerk are hereby authorized and directed to sign the Revocable License on behalf of the Borough, in substantially the form attached hereto.

BE IT FURTHER RESOLVED that the appropriate Borough officials and professionals are authorized to take all required actions to effectuate the authorizations in this Resolution and comply with the terms of the Revocable License.

Christine B. Ead, Council President

Ronald Jubin, Mayor

ADOPTED: AUGUST 15, 2024
INDEX: BOROUGH PROPERTIES, ENG,
C: ENG,

REVOCABLE LICENSE

THIS REVOCABLE LICENSE AGREEMENT (“LICENSE”) made this ____ day of _____, 2024, by and between:

THE BOROUGH OF WATCHUNG, a municipal corporation of the State of New Jersey with principal offices located at 15 Mountain Boulevard, Watchung, New Jersey, 07069 (“Licensor” or “Borough”);

and,

Amit H. Patel, having an address at 23 Blue Wolf Trail, Watchung, New Jersey, 07069 (“Licensee” or “Property Owner”).

W I T N E S S E T H

WHEREAS, the Licensee is the current owner of the property located at Block 43.04, Lot 17.11 in the Borough of Watchung, County of Somerset, State of New Jersey, located at 23 Blue Wolf Trail (the “Property”); and

WHEREAS, the Borough has an existing 20’ Wide Sanitary Sewer Easement traversing a portion of the Property (the “Easement”); and

WHEREAS, Licensee has requested a revocable license from the Borough to allow for the construction and location of a proposed fence across the Borough’s Easement at two (2) locations on the Property; and

WHEREAS, the Borough Engineer has reviewed the Licensee’s request and recommends that the Borough authorize this request conditioned upon the full execution of this Revocable License, which shall be recorded with the Somerset County Clerk’s Office, be binding on all successors of title to the Property, and run with the land; and

WHEREAS, the Borough finds it reasonable and appropriate to grant this Revocable License to the Property Owner for the location of the proposed fence across and within the Borough’s Easement on the Property.

NOW, THEREFORE, in consideration of \$1.00 paid by the Licensee, the promises and agreements contained herein, and for other good and valuable consideration herein acknowledged and accepted, the parties hereby agree as follows:

I. GRANTING OF LICENSE.

Licensor hereby grants to Licensee a revocable license to construct and maintain a six (6’) foot high pool/deer fence across and within the Borough’s Easement at two (2) locations on the Property, as proposed and designed on the plan entitled “Pool Plot Plan/Soil Erosion & Sediment

Control Plan,” dated June 3, 2021, revised through March 27, 2023, and prepared by Page-Mueller Engineering Consultants, Inc., which is attached **Exhibit A**.

Licensee’s usage of the License authorized herein shall be undertaken, performed, and completed in a good and workmanlike manner using suitable, quality materials, and in compliance with all applicable laws, ordinances, and regulations of all governmental authorities with jurisdiction.

II. TERM; TERMINATION OF LICENSE.

This License is granted at the pleasure of the Borough and may be terminated by the Borough, in its sole discretion, upon fifteen (15) days’ notice to the Licensee, the heirs, assigns or successors in interest. At the expiration of the 15-day notice period, the Borough is hereby authorized to record a License Termination Notice with the Somerset County Clerk’s Office, without further notice to the Property Owner, the heirs, assigns or successors in interest.

In the event this License is terminated by the Licensor, the Licensee shall remove the driveway within the Borough’s Easement within the fifteen (15) day notice period at their sole cost and expense. In the event the Licensee fails or refuses to complete such removal, the Borough shall have the right, not the obligation, to remove same at the cost and expense of the Property Owner, which may become a lien against the Property if such cost and expense is not paid within ten (10) days upon receipt of demand for payment by the Borough.

III. INSURANCE.

Licensee shall purchase and maintain during the term of this License a homeowner’s general liability insurance policy, with minimum limits of \$1,000,000.00 each occurrence, and \$1,000,000.00 general aggregate for bodily injury, personal injury and/or property damage liability combined. Licensor shall be included as an additional insured on the Licensee’s policies.

A Certificate of Insurance evidencing all of the coverages set forth herein shall be furnished to Licensor, with Licensor as a Certificate Holder, along with copies of endorsements providing evidence of all of the following: that Licensor is included as an additional insured; that notice of cancellation will be forwarded to the Licensor; and that waiver of subrogation applies with respect to any claims, damage or loss. At least fifteen (15) days prior to the expiration of such policies, Licensee shall furnish Licensor with renewal certificate(s) of insurance thereof.

IV. INDEMNIFICATION; HOLD HARMLESS.

Licensee, its successors, assigns, contractors, agents, servants, officers, employees, designees, guests and invitees, hereby indemnify, defend and hold harmless the Licensor, its successors and assigns, elected officials, officers, employees, servants, contractors, designees and invitees from and against any and all personal injury and property damage claims, demands, suits, actions at law or equity or otherwise, judgments, arbitration determinations, damages, liabilities, decrees of any person(s) or entities claiming to be or being harmed as a result of Licensee’s use of the licensed area. This indemnification shall specifically include, but not be limited to, any and all costs, reasonable attorney’s fees, court costs and any other expenses that may be incurred by the

Licensor in connection with any and all claims, demands, suits, actions at law or equity or otherwise and/or arbitration proceedings which may arise in connection with any claim for which the Licensor may or may not be claimed to be liable in whole or in part relating to this License. This provision shall survive termination of this License.

V. MISCELLANEOUS PROVISIONS.

- a. Assignment. This License shall not be assignable by Licensee.
- b. Modification. Except as otherwise provided herein, the provisions of this License shall not be amended or modified without the express written consent of both parties, and no such amendment or modification shall be effective for any purpose unless set forth in writing and signed by both parties.
- c. Notices. All notices shall be in writing and sent via certified mail, return receipt requested, overnight mail, or personal service to the addresses set forth hereinabove.
- d. Permits and approvals. Licensee shall be responsible for obtaining any and all applicable permits and approvals from all governmental authorities having jurisdiction over the Property and licensed area.
- e. Recordation. This License shall be recorded with the Somerset County Clerk's Office. The License shall be recorded by the Borough, with the costs of same to be the responsibility of the Property Owner.
- f. Attorney Fees. In the event that the Licensor must obtain the services of an attorney to enforce any provisions of this License, the Licensee shall be responsible for all attorneys' fees and court costs incurred by the Licensor.
- g. Entire Agreement. This agreement represents the entire agreement between the parties. All prior negotiations or oral promises or agreements are merged herein. Any and all changes to the within agreement shall be in writing and signed by all parties hereto.
- h. Controlling Law. This License shall be governed by and construed in accordance with the laws of the State of New Jersey.
- i. Counterparts. This License may be executed with original, faxed or e-mail signatures in one or more counterparts, each of which, when taken together, shall constitute a single original.

IN WITNESS WHEREOF, the parties hereto have hereunder set their hands and seals the day and year first written above.

ATTEST:

LICENSOR:

BOROUGH OF WATCHUNG

Edith Gil
Borough Clerk

By: _____
Ronald Jubin
Mayor

Dated: _____, 2024

ACKNOWLEDGMENT

STATE OF NEW JERSEY
COUNTY OF _____

SS:

I CERTIFY that on _____, 2024, **Amit H. Patel**, Property Owner, personally came before me and acknowledged under oath, to my satisfaction, that this person (or if more than one, each person):

- (a) was the maker of this License; and
- (b) was authorized to and did execute this License as owner of this property; and
- (c) made this License for: \$1.00 as for the full and actual consideration paid or to be paid for the rights granted herein. (Such consideration is defined in N.J.S.A. 46:15-5); and
- (d) executed this License as the act of the entity.

Notary Public of New Jersey

BOROUGH OF WATCHUNG

OFFICE OF THE ENGINEER

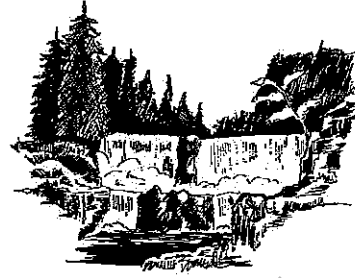

MEMO

DATE: June 19, 2024
TO: Edith Gil, Borough Clerk
FROM: Jason A. Cline, PE, PP. CME
RE: Revocable License Agreement
23 Blue Wolf Trail, Watchung, New Jersey
Block 43.04, Lot 17.11

The Borough of Watchung Engineering Department has reviewed the request by the homeowner at 23 Blue Wolf Trail to allow a fence to cross the 20-foot wide Borough of Watchung sanitary sewer easement that exists in the rear of the property.

At this time, neither the Engineering nor the Public Works Departments foresee any problems with the fence crossing the easement.

Please prepare a Revocable License Agreement including a Resolution for Council to allow this fence crossing to remain within the sanitary sewer easement.

Attached are the following for your use:

Three (3) copies of the marked up plan entitled Pool Plot Plan/Soil Erosion & Sediment Control Plan, dated revised 03/27/2023 by Page-Mueller Engineering Consultants, Inc.

Should you have any questions, whatsoever, please do not hesitate to contact me.

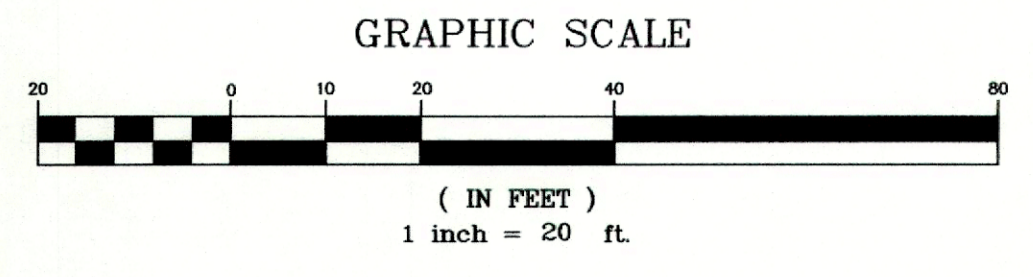

R=5105.00'
A=200.07'
B=N68°28'46"E
C=200.06'

INTERSTATE HIGHWAY ROUTE 78

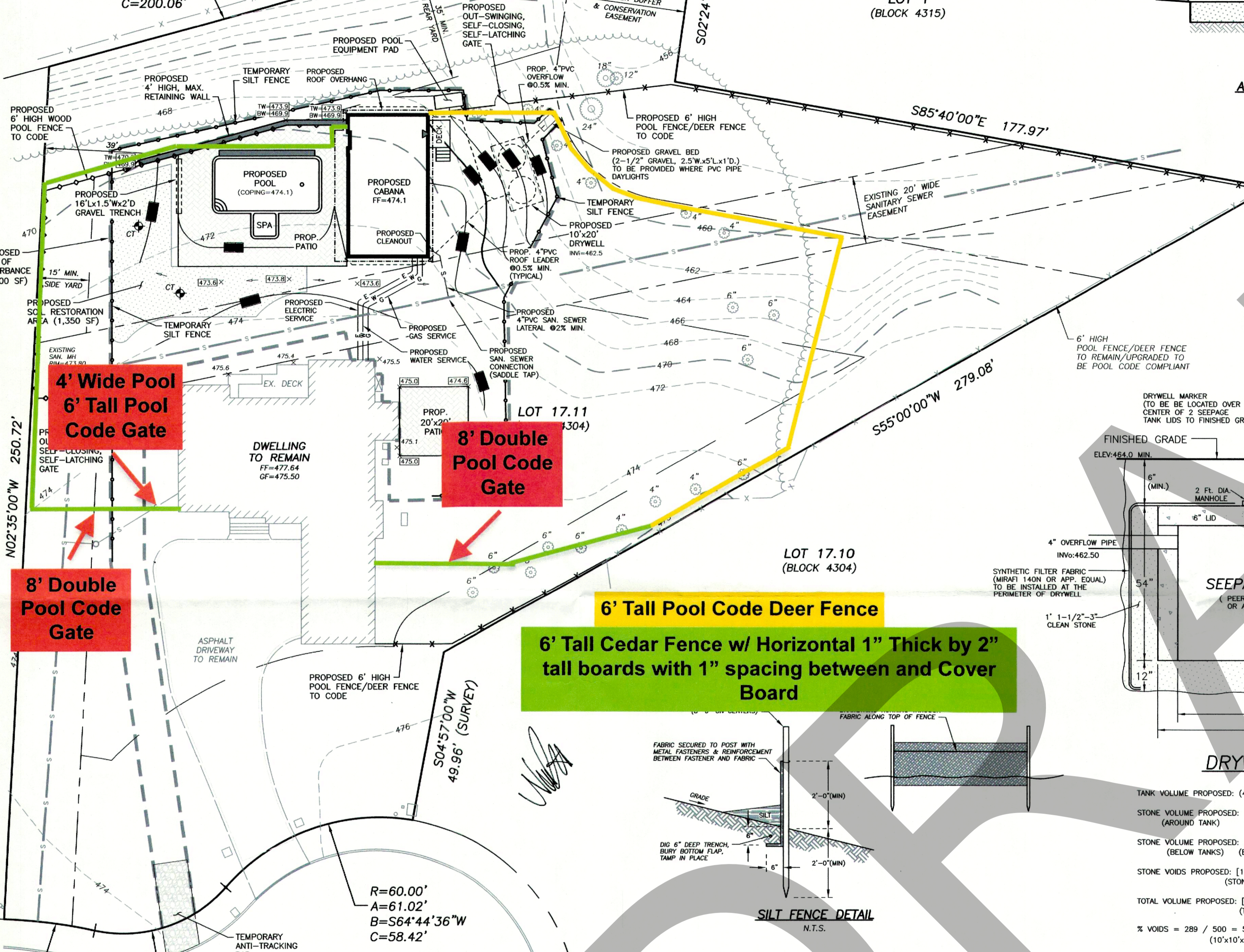

R=150.00'
A=26.87'
B=N88°26'42"W
C=26.83'

R=40.00'
A=42.64'
B=S66°08'53"W
C=40.65'

BLUE WOLF TRAIL

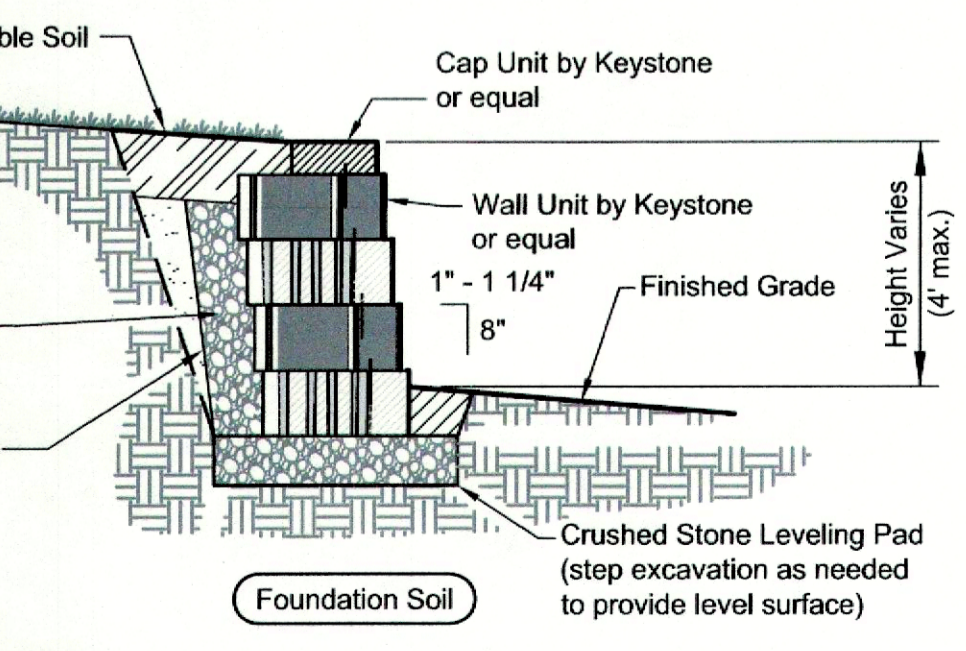

MODULAR BLOCK RETAINING WALL DETAIL N.T.S.

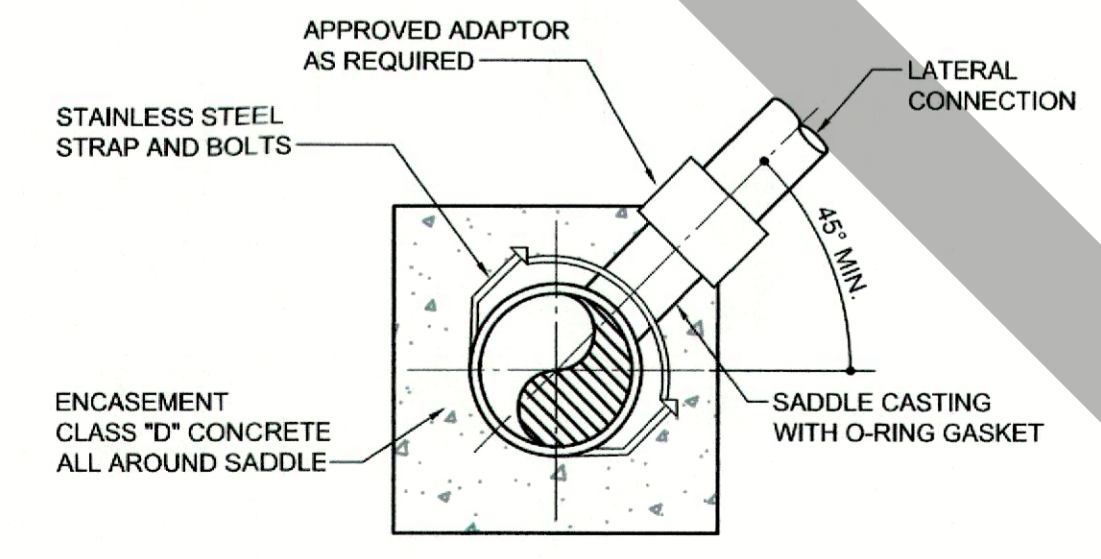

SADDLE TAP TO PIPE LATERAL DETAIL CONNECTION NOT TO SCALE

6' Tall Cedar Fence w/ Horizontal 1" Thick by 2" tall boards with 1" spacing between and Cover Board

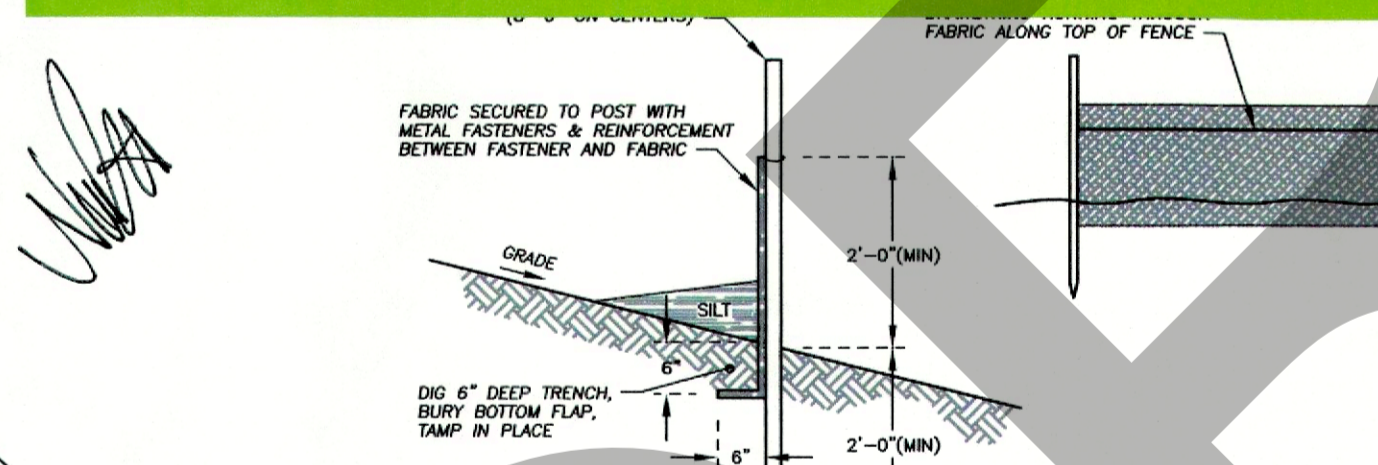

SILT FENCE DETAIL N.T.S.

DRYWELL DETAIL N.T.S.

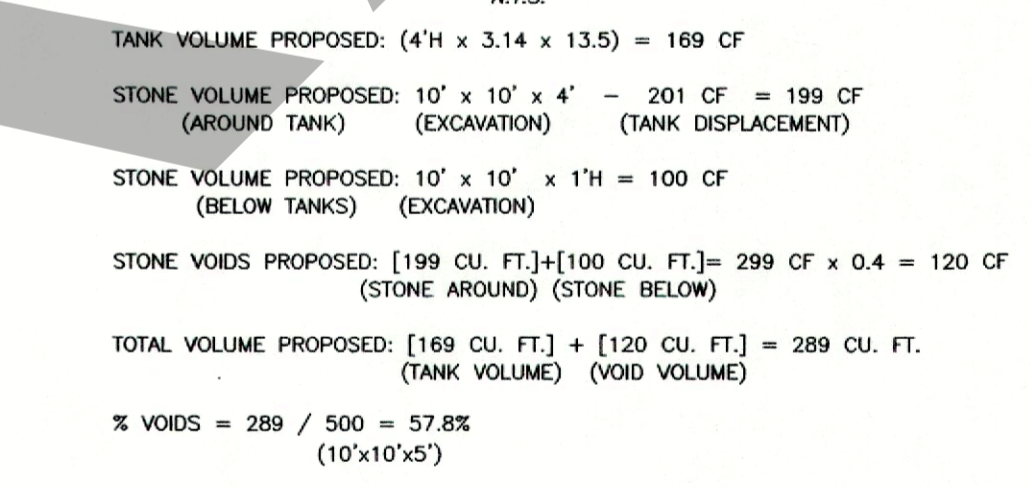

TANK VOLUME PROPOSED: (4'H x 3.14 x 13.5) = 169 CF
STONE VOLUME PROPOSED: 10' x 10' x 4' = 201 CF = 199 CF (AROUND TANK) (EXCAVATION) (TANK DISPLACEMENT)
STONE VOLUME PROPOSED: 10' x 10' x 1'H = 100 CF (BELOW TANKS) (EXCAVATION)
TOTAL VOLUME PROPOSED: [169 CU. FT.] + [100 CU. FT.] = 269 CF x 0.4 = 120 CF (STONE AROUND) (STONE BELOW)
TOTAL VOLUME PROPOSED: [169 CU. FT.] + [120 CU. FT.] = 289 CU. FT. (TANK VOLUME) (VOID VOLUME)
% VOIDS = 289 / 500 = 57.8% (10'x10'x5')

ZONING INFORMATION

	REQUIRED	EXISTING	PROPOSED
MIN. LOT AREA, TOTAL	40,000 SF	55,640 SF (1,277 AC.)	55,640 SF (1,277 AC.)
MIN. LOT WIDTH	125'	136.10'	136.10'
MIN. LOT FRONTAGE	100'	130.53'	130.53'
MIN. FRONT YARD	50'	50.71'	50.71'
MIN. SIDE YARD (EACH)	15'	20.41'	20.41'
MIN. SIDE YARD (BOTH)	30'	63.35'	63.35'
MIN. REAR YARD	35'	100.1'±	100.1'±
MIN. SIDE YARD (EACH)	15'	NA	39'
MIN. SIDE YARD (BOTH)	30'	NA	102'
MIN. REAR YARD	35'	NA	35'
MAX. BUILDING COVERAGE	9,737 SF 17.5%	3,204 SF 5.8%	4,233 SF 7.6%

	EXISTING IMPERVIOUS COVERAGE	PROPOSED IMPERVIOUS COVERAGE
DWELLING	3,204 SF	3,204 SF
DRIVEWAY	2,704 SF	2,704 SF
DECK	188 SF	188 SF
LANDING/STEPS/MISC.	108 SF	108 SF
PROPOSED CABANA	6,204 SF	1,029 SF
PROPOSED DECK/STEPS/MISC.		143 SF
PROPOSED POOL/SPA		517 SF
PROPOSED COPING		80 SF
PROPOSED PATIOS		1,800 SF
		9,773 SF (3,569 SF INCREASE)

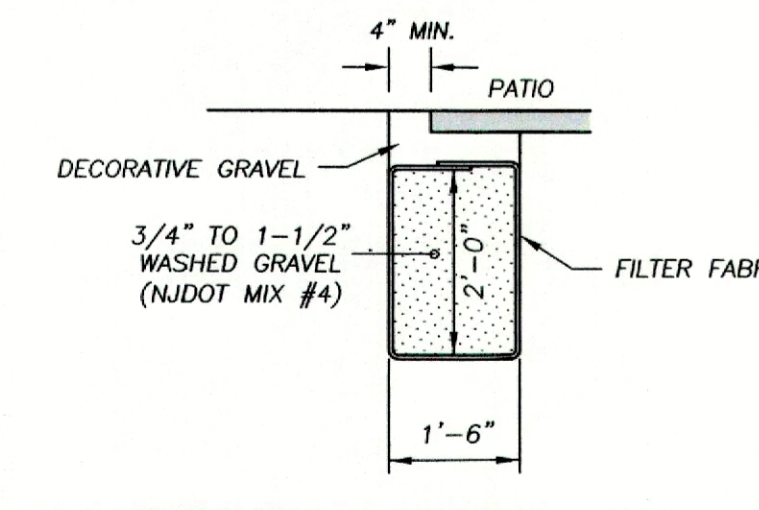

INFILTRATION TRENCH DETAIL N.T.S.

[351 SQ. FT.] x [0.25 FT.] = 88 CU. FT. (3" RAINFALL)
STONE VOLUME PROPOSED: [112' L.] x [1' W.] x [20' D.] = 224 CU. FT.
STONE VOIDS PROPOSED: [224 CU. FT.] x [0.4] = 90 CU. FT. (STONE VOL.) (RATIO)

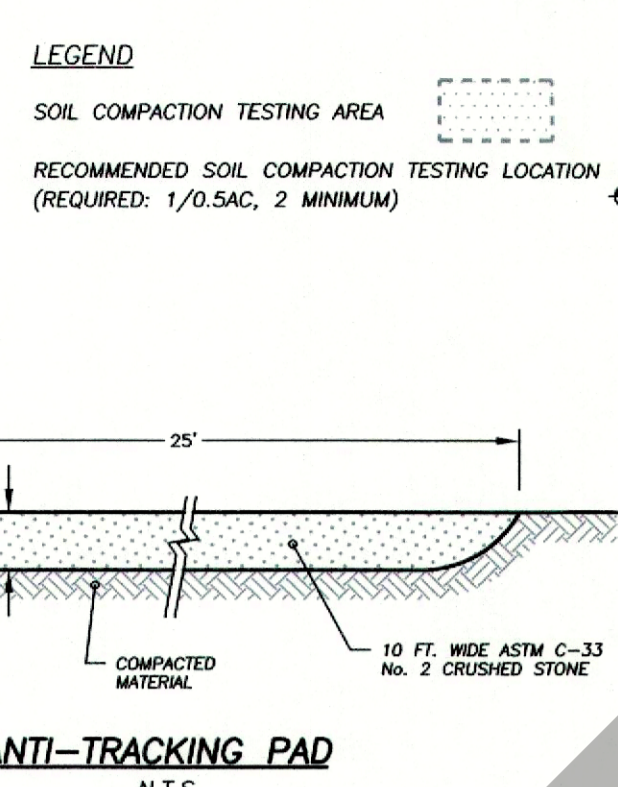

ANTI-TRACKING PAD N.T.S.

SOIL DE-COMPACTION AND TESTING REQUIREMENTS

- SOIL COMPACTION TESTING REQUIREMENTS**
- SUBGRADE SOILS PRIOR TO THE APPLICATION OF TOPSOIL (SEE PERMANENT SEEDING AND STABILIZATION NOTES FOR TOPSOIL REQUIREMENTS) SHALL BE FREE OF EXCESSIVE COMPACTION TO A DEPTH OF 6.0 INCHES TO ENHANCE THE ESTABLISHMENT OF PERMANENT VEGETATIVE COVER.
 - AREAS OF THE SITE WHICH ARE SUBJECT TO COMPACTION TESTING AND/OR MITIGATION ARE GRAPHICALLY DENOTED ON THE CERTIFIED SOIL EROSION CONTROL PLAN. COMPACTION REMEDIATION AND TESTING NOT REQUIRED WITHIN 20' OF A FOUNDATION WITH BASEMENT, WITHIN 12' OF A FOUNDATION WITH A SLAB OR CRAWL SPACE OVER A SEPTIC SYSTEM, WHERE THE AREA AVAILABLE FOR REMEDIATION PRACTICES IS 500 SQUARE FEET OR LESS IN SIZE, OR ANY OTHER AREAS DEEMED UNSUITABLE FOR ADDED INFILTRATION.
 - COMPACTION TESTING LOCATIONS ARE DENOTED ON THE PLAN. A COPY OF THE PLAN OR PORTION OF THE PLAN SHALL BE USED TO MARK LOCATIONS OF TESTS, AND ATTACHED TO THE COMPACTION MITIGATION VERIFICATION FORM, AVAILABLE FROM THE LOCAL SOIL CONSERVATION DISTRICT. THIS FORM MUST BE FILLED OUT AND SUBMITTED PRIOR TO RECEIVING A CERTIFICATE OF COMPLIANCE FROM THE DISTRICT.
 - IN THE EVENT THAT TESTING INDICATES COMPACTION IN EXCESS OF THE MAXIMUM THRESHOLDS INDICATED FOR THE SIMPLIFIED TESTING METHODS (SEE DETAILS BELOW), THE CONTRACTOR/OWNER SHALL HAVE THE OPTION TO PERFORM EITHER (1) COMPACTION MITIGATION OVER THE ENTIRE MITIGATION AREA DENOTED ON THE PLAN (EXCLUDING EXEMPT AREAS), OR (2) PERFORM ADDITIONAL, MORE DETAILED TESTING TO ESTABLISH THE LIMITS OF EXCESSIVE COMPACTION WHEREUPON ONLY THE EXCESSIVELY COMPACTED AREAS WOULD REQUIRE COMPACTION MITIGATION. ADDITIONAL DETAILED TESTING SHALL BE PERFORMED BY A TRAINED, LICENSED PROFESSIONAL ENGINEER.
- COMPACTION TESTING METHODS**
- PROBING WIRE TEST (SEE DETAIL)
 - HAND-HELD PENETROMETER TEST (SEE DETAIL)
 - TUBE BULK DENSITY TEST (LICENSED PROFESSIONAL ENGINEER REQUIRED)
 - NUCLEAR DENSITY TEST (LICENSED PROFESSIONAL ENGINEER REQUIRED)
- NOTE: ADDITIONAL TESTING METHODS WHICH CONFORM TO ASTM STANDARDS AND SPECIFICATIONS, AND WHICH PRODUCE A DRY WEIGHT, SOIL BULK DENSITY MEASUREMENT MAY BE ALLOWED, SUBJECT TO DISTRICT APPROVAL. DETAILED REQUIREMENTS FOR EACH COMPACTION TESTING METHOD CAN BE FOUND IN SECTION 19 "STANDARDS FOR LAND GRADING" OF THE NJ STANDARDS FOR SOIL EROSION AND SEDIMENT CONTROL, LATEST EDITION.

SOIL COMPACTION TESTING IS NOT REQUIRED IF WHEN SUBSOIL COMPACTION REMEDIATION (SCARIFICATION/TILLAGE (6" MINIMUM DEPTH) OR SIMILAR) IS PROPOSED AS PART OF THE SEQUENCE OF CONSTRUCTION.

PROCEDURES FOR SOIL COMPACTION MITIGATION

PROCEDURES SHALL BE USED TO MITIGATE EXCESSIVE SOIL COMPACTION PRIOR TO PLACEMENT OF TOPSOIL AND ESTABLISHMENT OF PERMANENT VEGETATIVE COVER.

RESTORATION OF COMPACTED SOILS SHALL BE THROUGH DEEP SCARIFICATION/TILLAGE (6" MINIMUM DEPTH) WHERE THERE IS NO DANGER TO UNDERGROUND UTILITIES (CABLES, IRRIGATION SYSTEMS, ETC.). IN THE ALTERNATIVE, ANOTHER METHOD AS SPECIFIED BY A NEW JERSEY LICENSED PROFESSIONAL ENGINEER MAY BE SUBSTITUTED SUBJECT TO DISTRICT APPROVAL.

Simplified Testing Methods

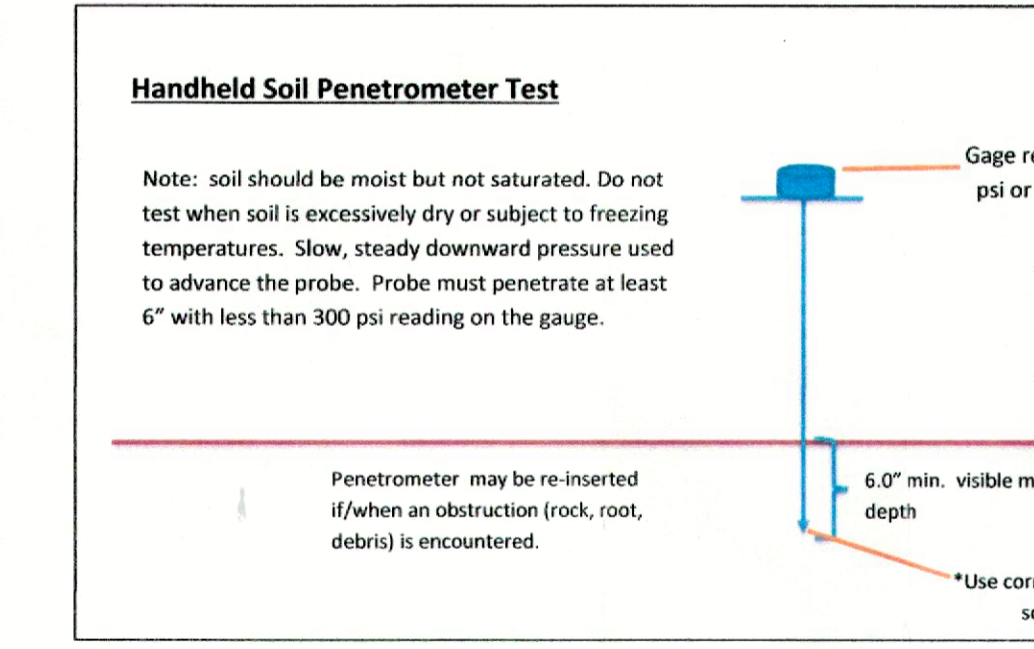
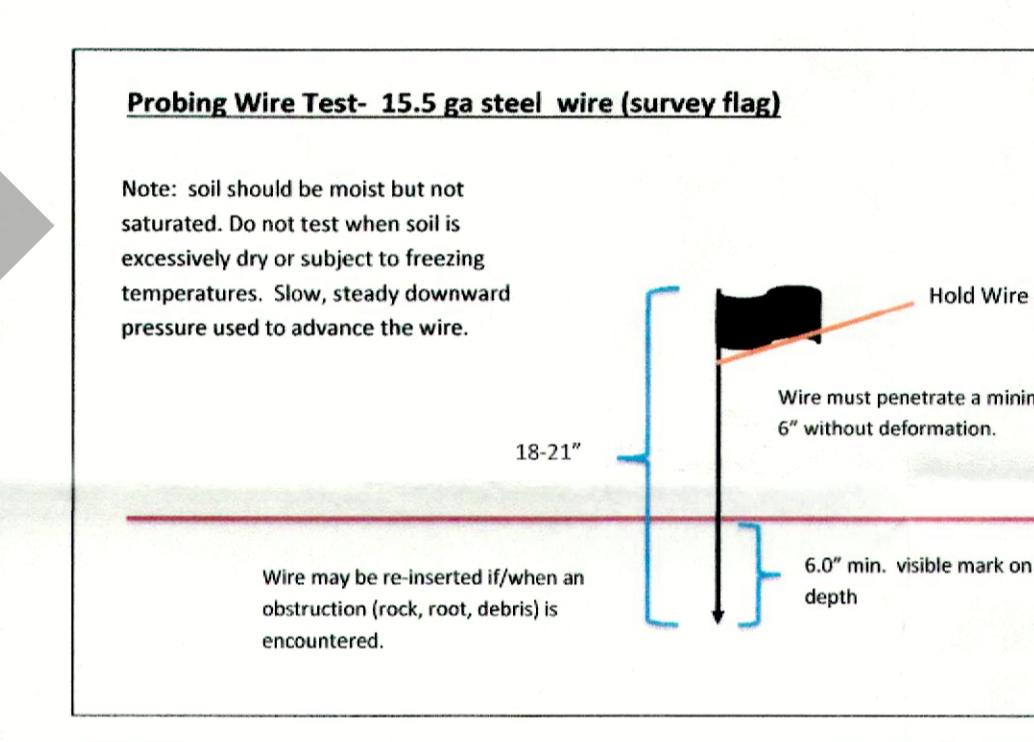

VEGETATION STABILIZATION NOTES:

- TEMPORARY VEGETATIVE COVER TO BE ESTABLISHED ON SOILS EXPOSED FROM 1 TO 12 MONTHS
 - ADD LIMESTONE AT A RATE ESTABLISHED VIA SOIL TESTING AND 10-10-10 FERTILIZER AT A RATE OF 600 LBS/ACRE
 - PLANT AS FOLLOWS:

BEFORE MAY 20: ANNUAL Ryegrass	40 LBS/ACRE
MAY 20 - JUNE 20: SUBANGRASS	60 LBS/ACRE
JUNE 20 - AUG: 1 WEEDING LOVEGRASS	30 LBS/ACRE
AUG. 15 - OCT: 15 ANNUAL Ryegrass	40 LBS/ACRE
OR APRIL - OCT: KOREAN LESPEDEZA	25 LBS/ACRE, IF ADEQUATE SOIL MOISTURE IS MAINTAINED
- PERMANENT VEGETATIVE COVER - GENERAL AREAS UNDER 5% SLOPE
 - ADD LIMESTONE AT A RATE ESTABLISHED VIA SOIL TESTING AND 10-20-10 FERTILIZER AT A RATE OF 600 LBS/ACRE OR ACCORDING TO RESULTS OF SOIL TESTS
 - 54% KENTUCKY 31 FESCUE, 5% RED TOP and 3% INERT (SOMETIMES DESIGNATED AS ATHLETIC FIELD MIXTURE), 100 LBS/ACRE
- PERMANENT VEGETATIVE COVER - CRITICAL AREAS - OVER 5% SLOPE
 - ADD LIMESTONE AT A RATE ESTABLISHED VIA SOIL TESTING AND 10-20-10 FERTILIZER AT A RATE OF 600 LBS/ACRE OR ACCORDING TO RESULTS OF SOIL TESTS
 - SEED WITH 50 LBS OF KENTUCKY 31 FESCUE AND 10 LBS CROWN VETCH/ACRE
- MULCHING IS REQUIRED ON ALL SEEDING. MULCH WILL INSURE AGAINST EROSION BEFORE GRASS IS ESTABLISHED AND WILL PROMOTE FASTER AND EARLIER ESTABLISHMENT.
 - THE FOLLOWING MATERIALS ARE SUITABLE FOR MULCHING - UNROOTED STRAW OR SALT HAY 1-1/2 TO 2 TONS/ACRE, WOOD FIBER OR PAPER OR PAPER FIBER (HYDRO-SEEDING 1500 LBS/ACRE), MULCH NETTING (PAPER, JUTE, EXCELSIOR, COTTON OR PLASTIC)
 - STRAW OR SALT HAY MULCHERS SHOULD BE IMMEDIATELY ANCHORED USING PEG TWINE NETTING, A MULCH ANCHORING TOOL OR LIQUID MULCH BINDERS.
- ALL DISTURBED AREAS NOT SCHEDULED FOR CONSTRUCTION ACTIVITIES WITHIN 30 DAYS OF DISTURBANCE SHALL BE STABILIZED WITH PERMANENT VEGETATIVE COVER.
- ALL ROADSIDE SWALES AND ROAD BANKS ARE TO BE STABILIZED IMMEDIATELY AFTER CONSTRUCTION.
- TOPSOIL SHOULD BE HANDLED ONLY WHEN IT IS DRY ENOUGH TO WORK WITHOUT DAMAGING THE SOIL STRUCTURE. A UNIFORM APPLICATION TO A DEPTH OF 5 INCHES (UNSETTLED) IS REQUIRED ON ALL SITES. TOPSOIL SHALL BE AMENDED WITH ORGANIC MATTER, AS NEEDED, IN ACCORDANCE WITH THE STANDARD FOR TOPSOILING.

RECOMMENDED SEQUENCE OF CONSTRUCTION

- ALL APPROPRIATE UTILITY COMPANIES ARE TO BE CONTACTED PRIOR TO ANY CONSTRUCTION.
- PROVIDE ANTI-TRACKING PAD AND SILT FENCE AS SHOWN. (1 DAY)
- REMOVE ALL IMPROVEMENTS MARKED FOR REMOVAL. (1 DAY)
- STRIP TOPSOIL. (1/2 DAY)
- ROUGH GRADE DISTURBANCE AREA. (1 DAY)
- BEGIN POOL & CABANA CONSTRUCTION. (2 MONTHS)
- INSTALL UTILITIES (1 WEEK)
- FINE GRADE SITE, APPLY 5" TOPSOIL, AND STABILIZE ALL DISTURBED AREAS. (1 WEEK)
- REMOVE ALL SOIL EROSION CONTROL DEVICES AS FINAL ITEM. (1/2 DAY)

PM EC PAGE-MUELLER ENGINEERING CONSULTANTS, PC
POST OFFICE BOX 4619
WARREN, NEW JERSEY 07059
(732) 805 - 3979 • FAX (732) 805 - 3978

CATHERINE A. MUELLER, P.E.
NEW JERSEY PROFESSIONAL ENGINEER LICENSE NO. GE44252

REVISED 3/27/23: ADDED SIDE PATIO
REVISED 8/15/22: PER SCD COMMENTS (8/12/22)
REVISED 7/1/21: LABELED SILT FENCE
project name
**23 BLUE WOLF TRAIL
BLOCK 4304: LOT 17.11**
(TAX MAP SHEET 13)
BOROUGH OF WATCHUNG
SOMERSET COUNTY, NEW JERSEY

drawing no. **POOL PLOT PLAN/SOIL EROSION & SEDIMENT CONTROL PLAN** 1 OF 1
drawn by TBB/RW checked by CAM date 6/3/21 scale 1"=20' project no. 2180

**BOROUGH OF WATCHUNG
RESOLUTION: R8**

WHEREAS, the Borough of Watchung awarded a contract to MTM Metro Corp, 135-137 McBride Avenue, Paterson, NJ 07501, on May 16, 2024, via resolution R8 for the removal and disposal of asbestos containing material at the Watchung Library in the amount of \$89,000.00; and

WHEREAS, the Borough's Administrator, have recommended the approval of **Change Order #1**, increasing the original contract by \$12,000.00 to provide for unforeseen adjustments in removing approximately 800 sq. ft. plaster from walls and ceilings; and

WHEREAS, the Chief Financial Officer of the Borough of Watchung has certified that funds are available in the following account: C-02-244-A11

William J. Hance, CFO

NOW, THEREFORE, BE IT RESOLVED, by the Mayor and Council of the Borough of Watchung, County of Somerset, State of New Jersey that **Change Order #1** to the contract of **MTM Metro Corporation** for a net increase of **\$12,000.00** is hereby approved and the contract sum, including this Change Order, is \$101,000.00.

BE IT FURTHER RESOLVED, that the Mayor and Borough Officials are hereby authorized to sign the Change Order form.

BE IT FURTHER RESOLVED, that a true copy of this Resolution be forwarded to: MTM Metro Corporation., the Borough Engineer and the Borough Chief Financial Officer.

Christine Ead, Council President

Ronald Jubin, Ph.D., Mayor

ADOPTED: AUGUST 15, 2024
INDEX: AWARDS, FINANC-MISC
C: B. HANCE,

BOROUGH OF WATCHUNG
 15 Mountain Boulevard
 Watchung, NJ 07069
 TEL (908)756-0080 FAX (908)757-7027

SHIP TO	WATCHUNG MUNICIPAL BUILDING 15 MOUNTAIN BLVD. WATCHUNG, NJ 07069-6399
	VENDOR # : MTMMETRO MTM Metro Corp. 135-137 McBride Avenue Paterson, NJ 07501

PURCHASE ORDER	
THIS NUMBER MUST APPEAR ON ALL INVOICES, PACKING LISTS, CORRESPONDENCE, ETC.	
NO.	24-00598

ORDER DATE: 05/17/24
 REQUISITION NO:
 DELIVERY DATE:
 STATE CONTRACT:
 ACCOUNT NUM:

PAYMENT RECORD	
CHECK NO.	
DATE PAID	

NOTICE: TAX ID #22-6002382 - TAX EXEMPT

QTY/UNIT	DESCRIPTION	ACCOUNT NO.	UNIT PRICE	TOTAL COST
1.00	removal & disposal of asbestos Library	C-02- -244-All	89,000.0000	89,000.00
			TOTAL	89,000.00

CLAIMANT'S CERTIFICATION & DECLARATION	OFFICER'S CERTIFICATION	APPROVAL TO PURCHASE
<p>I do solemnly declare and certify under penalties of the law that the within bill is correct in all its particulars; that the articles have been furnished or services rendered as stated therein; that no bonus has been given or received by any person or persons within the knowledge of this claimant in connection with the above claim; that the amount therein stated is justly due and owing; and that the amount charged is a reasonable one.</p> <p>X  VENDOR SIGN HERE</p> <p>Project Mgr OFFICIAL POSITION</p> <p>5/17/24 DATE</p> <p>TAX ID NO. OR SOCIAL SECURITY NO.</p>	<p>I, having knowledge of the facts, certify that the materials and supplies have been received or the services rendered; said certification being based on signed delivery slips or other reasonable procedures.</p> <p>DEPT. HEAD _____ DATE _____</p> <p>VENDOR MUST SIGN CERTIFICATION STATEMENT ON THIS VOUCHER, MAIL VOUCHER & ITEMIZED BILLS TO: BOROUGH OF WATCHUNG 15 Mountain Boulevard Watchung, NJ 07069</p>	<p>DO NOT ACCEPT THIS ORDER UNLESS IT IS SIGNED BELOW.</p> <p> CFO/QPA _____</p> <p>COUNCIL APPROVAL CAN BE SEEN _____</p> <p>ON BILL LIST RESOLUTION _____</p>



MTM Metro Corporation
 135-137 Mc Bride Avenue
 Paterson, NJ 07501
 www.mtmmetro.com
 973-742-5030

Invoice

Date	Invoice #
6/23/2024	2024-018

Bill To

Borough of Watchung
 15 Mountain Blvd
 Watchung, NJ

Ship To

Watchung Library
 Stirling Rd
 Watchung, NJ 07069

P.O. No.	Terms	Project
24-00598	Due on receipt	Watchung Library

Item	Description	Amount
NJ Asbestos Abatement	Removal of ACM from Watchung Public Library P.O. 24-00598	89,000.00
NJ Asbestos Abatement	Change Order Request: Removal of approximate 800 sq ft plaster from walls and ceilings @ \$15 per sq ft	12,000.00
<p>----- CHANGE ORDER ----- June 4, 2024 > Added 1 NJ Asbestos Abatement. (+\$12,000.00) Total change to estimate +\$12,000.00</p>		

On behalf of MTM Metro Corporation we thank you for this opportunity to be of service

NOTICE: Accounts 30 days past due-Customer is responsible for 1-1/2% per month interest (18%APR) and all legal and collection fees.

Visit us on the web at www.mtmmetro.com

Total	\$101,000.00
Payments/Credits	\$0.00
Balance Due	\$101,000.00



Westchester Environmental

CERTIFICATE OF COMPLETION

DATE: 06/15/2024

CLIENT: Borough of Watchung
15 Mountain Blvd.
Watchung, NJ 07069

To Whom It May Concern

This is to certify that asbestos abatement was completed at the location mentioned below in accordance with the State of New Jersey regulations NJAC 5:23-8 (Subchapter 8).

School: Watchung Public Library, 12 Stirling Road, Watchung, NJ 07069

Work Area(s): Main Building (WA 1) & Basement (WA 2)

The final air clearance samples checked by Transmission Electron Microscopy (TEM) indicated that all the results were in compliance with the applicable regulations.

WESTCHESTER ENVIRONMENTAL LLC

ASBESTOS SAFETY TECHNICIAN:

Peter Umoren

PRINT NAME OF AST:

Peter Umoren

AST#:

01313

ASCM#:

00127

ATC

2 MORICHES MIDDLE ISLAND ROAD
SHIRLEY, N.Y. 11967

Phone (631) 924-5050
Fax (631) 924-5085

NYS DEC 1A-371
NYC BIC #130
NJ DEP SW-24310

450844

Emergency Response
1-800-633-8253
PERS # 8939

Waste Manifest # 241380	Job #	Floor or Location Watchung Branch	Cust # 524-05-24
1. Work Site Name and Mailing Address Somerset County Library System of NJ 12 Stirling Road Watchung, NJ Somerset County (973) 742-5030		Generator Name, Address, Phone Number Borough of Watchung 15 Mountain Boulevard Watchung, NJ (908) 756-0080	
Contractor's Name, Address MTM Metro Corporation 135-137 McBride Avenue Paterson, NJ 07501		Waste Disposal Site MINERVA ENTERPRISES 8955 MINERVA ROAD WAYNESBURG, OH 44688	
Name and Address of Responsible NESHAPS Agency U.S. EPA REGION II, 290 BROADWAY, NEW YORK, NY 10007			
Description of Materials <input checked="" type="checkbox"/> RQ NA2212, Asbestos, 9, PGIII ERG #171 <input type="checkbox"/> Other			
		Bags 300	Cubic Yds 100
		Drums or Boxes 24	OTHER -
Special Handling Instructions and Additional Information			
OPERATOR CERTIFICATION: This is to certify that the above-named materials are properly classified, described, packaged, marked and labeled, and are in proper condition for transportation according to the applicable regulations of the Department of Transportation.			
Printed/Type Name Janicel		Signature <i>[Signature]</i>	Date (M/DD/YY) 6/14/24
Transporter 1 (Acknowledgement of Receipt of Materials)			
Company Name and Address ATC 2 MORICHES MIDDLE ISLAND ROAD SHIRLEY, NY 11967		Signature: <i>[Signature]</i>	Telephone No. 631-924-5050
		Printed Name: Wilson Jones	Date 6-14-24
		Title: DRIVER	
Transporter 2 (Acknowledgement of Receipt of Materials)			
Company Name and Address ATC 2 MORICHES MIDDLE ISLAND ROAD SHIRLEY, NY 11967		Signature: <i>[Signature]</i>	Telephone No. 631-924-5050
		Printed Name: Juan Corallo	Date 6/14/24
		Title: DRIVER	
Discrepancy Indication Space:			
MINERVA ENTERPRISES 8955 MINERVA ROAD WAYNESBURG, OH 44688		Waste Disposal Site Owner or Operator's Certification (Receipt of Above Waste Accepted)	
Company Name and Address		Signature: <i>[Signature]</i>	Telephone No. 330-866-3435
		Printed Name: Gabe Sullivan	Date 6-19-24
		Title:	

**BOROUGH OF WATCHUNG
RESOLUTION: R9**

WHEREAS, Ophir Marko and Rinat Perah Basha Marko (“Owner”) are the owners of certain real property known as Block 6905, Lot 13 as shown on the Official Tax Map of the Borough of Watchung, County of Somerset, State of New Jersey, located at 636 Valley Road (the “Property”); and

WHEREAS, there is a stream that runs through the rear of the Property, as well as other surrounding residential properties, which stream is in need of repair; and

WHEREAS, the Borough of Watchung needs temporary access through and in a portion of the Property in order to complete the repairs to the stream; and

WHEREAS, in connection with any improvements being undertaken by Grantee, Grantor has agreed to convey a temporary construction access license (hereinafter defined) to Grantee on the temporary construction license area as identified in the Temporary Construction Access License Agreement, which the Owner is granting to the Borough.

NOW THEREFORE, BE IT RESOLVED, by the Mayor and Council of the Borough of Watchung, State of New Jersey that the Borough hereby authorizes the acceptance of the Temporary Construction Access License Agreement to allow the Borough temporary access to 636 Valley Road, known as Block 6905, Lot 13 for completion of the stream improvements.

BE IT FURTHER RESOLVED that the Mayor and Borough Clerk are hereby authorized and directed to sign the Temporary Construction Access License Agreement on behalf of the Borough, in substantially the form attached and reviewed by the Borough Attorney.

Christine Ead, Council President

Ronald Jubin, Ph.D., Mayor

ADOPTED: AUGUST 15, 2024
INDEX: PERMITS-SPECIAL,
C: ENG,

TEMPORARY CONSTRUCTION ACCESS LICENSE AGREEMENT

This Temporary Construction Access License Agreement (“License”) is made this ____ day of _____, 2024, by **OPHIR MARKO AND RINAT PERAH BASHA MARKO**, having an address of 636 Valley Road, Watchung, New Jersey 07069 (“Grantor”) and **THE BOROUGH OF WATCHUNG**, a Municipal Corporation of the State of New Jersey, having its principal office at 15 Mountain Boulevard, Watchung, New Jersey 07069 (“Grantee” or “Borough” or “Watchung”). Grantor and Grantee are sometimes hereinafter referred to individually as a “Party,” and collectively as the “Parties”;

WHEREAS, Grantor is the owner of certain real property known as Block 6905, Lot 13 as shown on the Official Tax Map of the Borough of Watchung, County of Somerset, State of New Jersey, located at 636 Valley Road (the “Property”); and

WHEREAS, there is a stream that runs through the rear of the Property, as well as other surrounding residential properties, which stream is in need of repair; and

WHEREAS, the Borough needs temporary access through and in a portion of the Property in order to complete the repairs to the stream; and

WHEREAS, the areas on the Property necessary for the Borough to perform such work cannot be specifically delineated, and as such the entire Property subject to this License shall be referred to as the “Temporary Construction License Area”; and

WHEREAS, in connection with any improvements being undertaken by Grantee, Grantor has agreed to convey a temporary construction access license (hereinafter defined) to Grantee on the Temporary Construction License Area.

NOW, THEREFORE, in consideration of One and 00/100 (\$1.00) Dollars, and other good and valuable consideration, the receipt and sufficiency of which is hereby acknowledged by Grantor, Grantor does hereby give, grant, convey, and assign unto Grantee, its successors, assigns, agents, contractors, engineers, consultants and/or designees, a temporary construction license to access and use in that portion of the Grantor’s property contained within the Temporary Construction License Area as described herein, upon the following terms and conditions.

1. **Preambles.** The above preambles of this License are hereby incorporated by reference herein.

2. **Purpose of Temporary Construction License.**

(a) This instrument shall convey to Grantee, its successors, assigns, agents, contractors, engineers, consultants and/or designees, as the case may be, on foot and with vehicles and machinery, the right to enter and re-enter the Temporary Construction License Area for the purpose of performing the necessary work to address and repair, to the best of Grantee's ability, the stream on the Property. Work that may be required for this project includes, without limitation, the excavating and grading of soil, swale and berm construction, replacement and regrading of existing stream banks, including the construction of a training wall, and installation of silt fence for soil erosion and sediment control.

(b) This instrument shall further convey the right unto Grantee to remove any trees, bushes, shrubs, undergrowth and/or any other obstructions from the Temporary Construction License Area adversely impacting the carrying out of the purposes as described herein, subject to reasonable prior notice and approval by Grantor. Grantee shall provide for the reasonable restoration of the disturbed areas, including placing of topsoil, seeding, fertilizing and mulching lawn areas, and reasonable replacement of landscaping as required.

(c) Grantor hereby reserves the right to grant such future licenses, easements and other right-of-ways, over, under, across and through the Temporary Construction License Area, provided same will not adversely affect Grantee's exercise of the rights granted herein.

(d) This License grant and all provisions herein are subordinate to the right of the Grantor, expressly reserved, to access and use the Temporary Construction License Area for any purpose which does not unreasonably interfere with Grantee's right to use the Temporary Construction License Area for the purposes set forth herein.

(e) The Parties acknowledge that the work to be performed in the Temporary Construction License Area by the Grantor may be performed by Borough employees or a

contractor awarded through a publicly bid contract for such services.

3. **Duration of License and Assignment of Rights.** The License shall commence upon the Grantor's receipt of written notification from the Grantee's Engineer, and shall remain in effect for a period of one (1) month or until certification by the Grantee's Engineer accepting final completion of the work, whichever is later ("Termination Date").

4. **Use of Temporary Construction License Area.** Except as hereinafter specifically set forth, Grantor, its successors and assigns, shall not install any fence, vegetation, landscaping, structure or other impediment in or on any portion of the Property that would unreasonably interfere with Grantee's use of the Temporary Construction License Area or Grantee's exercise of the rights conveyed herein. Grantee shall have the right, after conformance with this Section, to clear any such impediments and obstructions installed thereon by Grantor, at Grantor's sole cost and expense.

5. **Property of Grantee.** It is expressly understood and agreed that all property, tools, equipment, vehicles, excavation, debris, surplus materials, and improvements placed upon the Temporary Construction License Area shall remain the property of the Grantee, its successors and assigns, employees, agents, contractors and/or designees, as the case may be, and must be removed by the Grantee, its successors and assigns, its agents, contractors, engineers, consultants and/or designees, as the case may be, on or before the Termination Date.

6. **Indemnification.** It is expressly understood and agreed that Grantee indemnifies and holds Grantor, its successors and assigns, employees, engineers, consultants, agents, contractors and/or designees, as the case may be, harmless against any and all damages, conditions and claims arising out of the construction within the Temporary Construction License Area, except for those claims that may arise out of the Grantor's negligence or willful misconduct. The indemnification provided herein shall be limited by all applicable laws including the N.J. Tort Claims Act.

7. **Environmental Compliance.**

(a) Grantee covenants and agrees that, during the term of this License, Grantee shall be responsible, at its sole cost and expense, for the following (collectively, "Grantee's Environmental Obligations"): (i) the management and off-site disposal of all soils, groundwater or surface water excavated or removed from the Temporary Construction

License Area by Grantee or Grantee's employees, agents, contractors and/or designees ("Removed Materials"), and (ii) any releases of Hazardous Substances (as defined herein) on or at the Temporary Construction License Area caused by Grantee or Grantee's employees, agents, contractors and/or designees (a "Grantee Release"). It is understood that Grantor is not, and has no responsibility as a handler, generator, operator, treater, storer, arranger, transporter, or disposer of any Removed Materials. Grantee shall be designated as the generator in connection with the disposal of any Removed Materials and shall be responsible at its sole cost and expense for the management and disposal of all Removed Materials. If any investigation, reporting, sampling, site monitoring, containment, cleanup, removal, restoration or other remedial work of any kind or nature required under any state, federal or local statutes, regulations, laws and directives, including Environmental Laws (hereafter defined), ("Remedial Work") is necessary as a result of a Grantee Release, including in connection with Removed Materials, then Grantee shall: (i) immediately notify Grantor and provide Grantor with such information as reasonably required by Grantor in relation thereto, and (ii) at its expense, obtain a Response Action Outcome ("RAO") pursuant to New Jersey law in connection with such Remedial Work and shall pay all costs as may be required by the New Jersey Department of Environmental Protection ("NJDEP"). Any reports, sampling plans, remediation plans, financial assurances or such other documentation required for the Remedial Work shall first be submitted to Grantor for its prior approval. Grantee shall diligently prosecute to completion all Remedial Work in accordance with such approved plans and without imposition of any engineering or institutional controls on the Temporary Construction License Area or Grantor's property unless approved by Grantor, which approval shall not be unreasonably withheld, conditioned or delayed. Grantee hereby indemnifies, defends and holds Grantor and Grantor's successors and assigns harmless from and against and with respect to any and all Claims (hereafter defined) asserted against Grantor and/or Grantor's successors and assigns with respect to Grantee's Environmental Obligations and those obligations of Grantee set forth in this Section 7, except for those Claims that may arise out of: (i) Grantor's gross negligence or willful misconduct, or (ii) Existing Contamination Conditions (hereafter defined), as more particularly described in Section 8(b) below.

(b) Notwithstanding anything contained in this License to the contrary, Grantor does hereby assume and retain responsibility for and does hereby release Grantee and Grantee's successors and assigns, from, against and with respect to any and all actions, causes of action, complaints, claims, costs, damages, liabilities and losses (collectively, "Claims"), which Grantor and/or Grantor's successors and assigns, or anyone claiming through or under Grantor and/or Grantor's successors and assigns, may hereafter have against Grantee and/or Grantee's successors and assigns with respect to the presence of Hazardous Substances (as defined in this Section 7) existing on, at, under or originating from the Temporary Construction License Area (including soils, groundwater or any other media) as of the date of this License, except to the extent such conditions are caused by Grantee prior to date of this License (the "Existing Contamination Conditions") and Grantor further indemnifies, defends and holds Grantee and Grantee's successors and assigns harmless from and against and with respect to any and all Claims asserted by third parties against Grantee and/or Grantee's successors and assigns with respect to the Existing Contamination Conditions; provided, however, that Grantor does not release Grantee and Grantee's successors and assigns from, nor does Grantor agree to indemnify, defend or hold Grantee and Grantee's successors and assigns harmless from or with respect to Grantee's Environmental Obligations.

(c) As used in this Section 7, the term "Hazardous Substances" shall mean any toxic or hazardous substance, material or waste or any pollutant or contaminant or infectious or radiologically contaminated or enhanced material, including, but not limited to, those substances, chemicals, wastes, toxicants, pollutants, pesticides, fungicides or contaminants regulated by any Environmental Law (as defined herein), including, without limitation, any petroleum products or fractions thereof.

(d) As used in this Section 7, the term "Environmental Law" shall mean any one or all local, state, and federal laws, rules, statutes, ordinances and regulations, now in effect or hereinafter enacted, that regulate or protect health and the environment, and shall include without limitation, any law, rule, statute, ordinance, regulation, judicial or administrative order, or consent decree which governs or addresses the quality, management or use of any air, ground water, surface water, soil, land, or any subsurface or sub-strata land, or the generation, treatment, storage, disposal, use or disposition of any

Hazardous Substance including, without limitation, the New Jersey Industrial Site Recovery Act, N.J.S.A. 13:1K-6 et seq., the New Jersey Spill Compensation and Control Act, N.J.S.A. 58:10-23.11, et seq., the New Jersey Brownfield and Contaminated Site Remediation Act, N.J.S.A. 58:10B-1 et seq., the New Jersey Site Remediation Reform Act, N.J.S.A. 58:10C-1 et seq., the NJDEP Technical Requirements for Site Remediation rules, at N.J.A.C. 7:26E-1, et seq., the NJDEP Administrative Requirements for the Remediation of Contaminated Sites, N.J.A.C. 7:26C-1, et seq. (the “ARRCS Rules”), and any amendments of such laws, regulations and codes and any successor thereto, as amended.

(e) The provisions of this Section 8 shall survive the expiration or termination of this License.

8. **Binding Effect.** By acceptance of this instrument, Grantor and Grantee agree to abide by the terms and conditions herein, and the provisions of this instrument shall inure to the benefit of and be binding upon the respective Parties hereto and their heirs, executors, administrators, successors, and assigns. The rights granted hereunder may not be assigned and transferred by Grantee, without the prior written consent of Grantor, which shall be in Grantor’s sole discretion.

9. **Severability.** If any of the provisions of this instrument shall be deemed invalid or unenforceable, such invalidity or unenforceability shall not invalidate or render unenforceable the entire instrument, but rather the entire instrument shall be construed as if not containing the particular invalid or unenforceable provision or provisions, and the rights and obligations of Grantor and Grantee shall be construed and enforced accordingly. Grantor assumes no responsibility or liability for any condition which may be disclosed by the entry onto the lands and interests being conveyed herein.

10. **Counterparts.** This instrument may be executed in one or more counterparts, together which shall constitute the same instrument.

11. **Insurance.** Grantee shall maintain in full force and effect Comprehensive General Liability (including Contractual Liability covering this agreement), Automobile Liability and Employer Liability insurance with minimum limits of \$1,000,000 per occurrence for both bodily injury and property damage. Workmen’s Compensation coverage shall be the minimum statutory limits required by law. Grantor shall maintain in full force and effect property owner’s insurance covering the Property, which shall contain comprehensive general liability coverage. In addition,

Grantee shall require that its contractors performing the work in the Temporary Construction License Area maintain the same insurance requirements, naming the Grantor as an additional insured on the policies. On request, each party shall provide evidence of each policy of insurance obtained or maintained as required herein.

12. **Terms of License.**

(a) Grantee agrees that all work to be performed pursuant to the rights granted herein shall be performed in a safe, good and workmanlike manner, with due regard for the safety of persons and the property of Grantor and others, and in conformity with all applicable governmental statutes, ordinances, rules and regulations, permits and approvals.

(b) Grantee shall not impair, restrict or prevent free, ready and continuous passage by Grantor or its agents, invitees, licensees, successor and assigns, over the Temporary Construction License Area except on a temporary basis as reasonably necessary during construction or maintenance, and upon at least twenty-four (24) hours' prior written notice to Grantor, except that in the event of an emergency, notice shall be given as promptly as possible.

(c) Notwithstanding anything to the contrary herein, the rights provided for herein are subject to any and all existing rights of way, interests, conditions, leases, easements and restrictions currently in effect for the Temporary Construction License Area.

(d) No mechanic's or other lien for such labor or materials shall attach to or affect any estate or interest of Grantor in and to all or any portion of Grantor's Property. If any vendor's, mechanic's, laborer's or materialman's statutory or similar lien is filed or claimed against Grantor's property or any other property owned by Grantor by reason of work, labor, services or materials supplied or claimed to have been supplied to all or any portion of the Temporary Construction License Area by Grantee, Grantee shall promptly after notice of such filing or claim, cause the same to be discharged of record or bonded.

13. **NO GUARANTY/WARRANTY.** The parties acknowledge and agree that the Borough is making no guaranty and not providing any warranty that the work being performed will address all the issues that may exist relating to the stream on the Property, including, without limitation, that such work will ultimately solve any stormwater issues or not cause any future issues or damages to the Property. The Parties further acknowledge and agree that the Borough's

performance of such work herein authorized is being done to address any future public concerns; and is not assuming any ongoing maintenance, repair, nor any easement or other property interest in the Property or the improvements being provided thereon. The Property remains private property; and any and all future maintenance, repair or other work required on the Property shall remain the responsibility of the Grantor.

14. **Self Help.** If a party fails to perform, fulfill or observe any agreement contained within this License on its part to be performed, fulfilled or observed, that continues for thirty (30) days after written notice, or if an emergency exists that threatens damage to persons or property, or any portion or any part thereof, the other party, at its election, may cure such failure or breach on behalf of the breaching party. Any amount that is expended to remedy any breach shall be reimbursed by the breaching party to the other party within ten (10) business days after presentation of an invoice for such services.

[Signature page follows.]

IN WITNESS WHEREOF, by execution of this License, Grantor has accepted the terms of this Temporary Construction License the day and year first above written.

WITNESS:

Name:

Dated: _____, 2024

GRANTOR:

Ophir Marko

WITNESS:

Name:

Dated: _____, 2024

Rinat Perah Basha Marko

WITNESS:

Edith Gil, Borough Clerk

Dated: _____, 2024

GRANTEE:

Ronald Jubin, Mayor

**BOROUGH OF WATCHUNG
RESOLUTION: R10**

WHEREAS, Gerhard Liepold and Sigrid Liepold (“Owner”) are the owners of certain real property known as Block 6905, Lot 4 as shown on the Official Tax Map of the Borough of Watchung, County of Somerset, State of New Jersey, located at 10 Friar Lane (the “Property”); and

WHEREAS, there is a stream that runs through the rear of the Property, as well as other surrounding residential properties, which stream is in need of repair; and

WHEREAS, the Borough of Watchung needs temporary access through and in a portion of the Property in order to complete the repairs to the stream; and

WHEREAS, in connection with any improvements being undertaken by Grantee, Grantor has agreed to convey a temporary construction access license (hereinafter defined) to Grantee on the temporary construction license area as identified in the Temporary Construction Access License Agreement, which the Owner is granting to the Borough.

NOW THEREFORE, BE IT RESOLVED, by the Mayor and Council of the Borough of Watchung, State of New Jersey that the Borough hereby authorizes the acceptance of the Temporary Construction Access License Agreement to allow the Borough temporary access to 10 Friar Lane, known as Block 6905, Lot 4 for completion of the stream improvements.

BE IT FURTHER RESOLVED that the Mayor and Borough Clerk are hereby authorized and directed to sign the Temporary Construction Access License Agreement on behalf of the Borough, in substantially the form attached and reviewed by the Borough Attorney.

Christine Ead, Council President

Ronald Jubin, Ph.D., Mayor

ADOPTED: AUGUST 15, 2024
INDEX: PERMITS-SPECIAL,
C: ENG,

TEMPORARY CONSTRUCTION ACCESS LICENSE AGREEMENT

This Temporary Construction Access License Agreement (“License”) is made this ____ day of _____, 2024, by **GERHARD LIEPOLD AND SIGRID LIEPOLD**, having an address of 10 Friar Lane, Watchung, New Jersey 07069 (“Grantor”) and **THE BOROUGH OF WATCHUNG**, a Municipal Corporation of the State of New Jersey, having its principal office at 15 Mountain Boulevard, Watchung, New Jersey 07069 (“Grantee” or “Borough” or “Watchung”). Grantor and Grantee are sometimes hereinafter referred to individually as a “Party,” and collectively as the “Parties”;

WHEREAS, Grantor is the owner of certain real property known as Block 6905, Lot 4 as shown on the Official Tax Map of the Borough of Watchung, County of Somerset, State of New Jersey, located at 10 Friar Lane (the “Property”); and

WHEREAS, there is a stream that runs through the rear of the Property, as well as other surrounding residential properties, which stream is in need of repair; and

WHEREAS, the Borough needs temporary access through and in a portion of the Property in order to complete the repairs to the stream; and

WHEREAS, the areas on the Property necessary for the Borough to perform such work cannot be specifically delineated, and as such the entire Property subject to this License shall be referred to as the “Temporary Construction License Area”; and

WHEREAS, in connection with any improvements being undertaken by Grantee, Grantor has agreed to convey a temporary construction access license (hereinafter defined) to Grantee on the Temporary Construction License Area.

NOW, THEREFORE, in consideration of One and 00/100 (\$1.00) Dollars, and other good and valuable consideration, the receipt and sufficiency of which is hereby acknowledged by Grantor, Grantor does hereby give, grant, convey, and assign unto Grantee, its successors, assigns, agents, contractors, engineers, consultants and/or designees, a temporary construction license to access and use in that portion of the Grantor’s property contained within the Temporary Construction License Area as described herein, upon the following terms and conditions.

1. **Preambles.** The above preambles of this License are hereby incorporated by reference herein.

2. **Purpose of Temporary Construction License.**

(a) This instrument shall convey to Grantee, its successors, assigns, agents, contractors, engineers, consultants and/or designees, as the case may be, on foot and with vehicles and machinery, the right to enter and re-enter the Temporary Construction License Area for the purpose of performing the necessary work to address and repair, to the best of Grantee's ability, the stream on the Property. Work that may be required for this project includes, without limitation, the excavating and grading of soil, swale and berm construction, replacement and regrading of existing stream banks, including the construction of a training wall, and installation of silt fence for soil erosion and sediment control.

(b) This instrument shall further convey the right unto Grantee to remove any trees, bushes, shrubs, undergrowth and/or any other obstructions from the Temporary Construction License Area adversely impacting the carrying out of the purposes as described herein, subject to reasonable prior notice and approval by Grantor. Grantee shall provide for the reasonable restoration of the disturbed areas, including placing of topsoil, seeding, fertilizing and mulching lawn areas, and reasonable replacement of landscaping as required.

(c) Grantor hereby reserves the right to grant such future licenses, easements and other right-of-ways, over, under, across and through the Temporary Construction License Area, provided same will not adversely affect Grantee's exercise of the rights granted herein.

(d) This License grant and all provisions herein are subordinate to the right of the Grantor, expressly reserved, to access and use the Temporary Construction License Area for any purpose which does not unreasonably interfere with Grantee's right to use the Temporary Construction License Area for the purposes set forth herein.

(e) The Parties acknowledge that the work to be performed in the Temporary Construction License Area by the Grantor may be performed by Borough employees or a

contractor awarded through a publicly bid contract for such services.

3. **Duration of License and Assignment of Rights.** The License shall commence upon the Grantor's receipt of written notification from the Grantee's Engineer, and shall remain in effect for a period of one (1) month or until certification by the Grantee's Engineer accepting final completion of the work, whichever is later ("Termination Date").

4. **Use of Temporary Construction License Area.** Except as hereinafter specifically set forth, Grantor, its successors and assigns, shall not install any fence, vegetation, landscaping, structure or other impediment in or on any portion of the Property that would unreasonably interfere with Grantee's use of the Temporary Construction License Area or Grantee's exercise of the rights conveyed herein. Grantee shall have the right, after conformance with this Section, to clear any such impediments and obstructions installed thereon by Grantor, at Grantor's sole cost and expense.

5. **Property of Grantee.** It is expressly understood and agreed that all property, tools, equipment, vehicles, excavation, debris, surplus materials, and improvements placed upon the Temporary Construction License Area shall remain the property of the Grantee, its successors and assigns, employees, agents, contractors and/or designees, as the case may be, and must be removed by the Grantee, its successors and assigns, its agents, contractors, engineers, consultants and/or designees, as the case may be, on or before the Termination Date.

6. **Indemnification.** It is expressly understood and agreed that Grantee indemnifies and holds Grantor, its successors and assigns, employees, engineers, consultants, agents, contractors and/or designees, as the case may be, harmless against any and all damages, conditions and claims arising out of the construction within the Temporary Construction License Area, except for those claims that may arise out of the Grantor's negligence or willful misconduct. The indemnification provided herein shall be limited by all applicable laws including the N.J. Tort Claims Act.

7. **Environmental Compliance.**

(a) Grantee covenants and agrees that, during the term of this License, Grantee shall be responsible, at its sole cost and expense, for the following (collectively, "Grantee's Environmental Obligations"): (i) the management and off-site disposal of all soils, groundwater or surface water excavated or removed from the Temporary Construction

License Area by Grantee or Grantee's employees, agents, contractors and/or designees ("Removed Materials"), and (ii) any releases of Hazardous Substances (as defined herein) on or at the Temporary Construction License Area caused by Grantee or Grantee's employees, agents, contractors and/or designees (a "Grantee Release"). It is understood that Grantor is not, and has no responsibility as a handler, generator, operator, treater, storer, arranger, transporter, or disposer of any Removed Materials. Grantee shall be designated as the generator in connection with the disposal of any Removed Materials and shall be responsible at its sole cost and expense for the management and disposal of all Removed Materials. If any investigation, reporting, sampling, site monitoring, containment, cleanup, removal, restoration or other remedial work of any kind or nature required under any state, federal or local statutes, regulations, laws and directives, including Environmental Laws (hereafter defined), ("Remedial Work") is necessary as a result of a Grantee Release, including in connection with Removed Materials, then Grantee shall: (i) immediately notify Grantor and provide Grantor with such information as reasonably required by Grantor in relation thereto, and (ii) at its expense, obtain a Response Action Outcome ("RAO") pursuant to New Jersey law in connection with such Remedial Work and shall pay all costs as may be required by the New Jersey Department of Environmental Protection ("NJDEP"). Any reports, sampling plans, remediation plans, financial assurances or such other documentation required for the Remedial Work shall first be submitted to Grantor for its prior approval. Grantee shall diligently prosecute to completion all Remedial Work in accordance with such approved plans and without imposition of any engineering or institutional controls on the Temporary Construction License Area or Grantor's property unless approved by Grantor, which approval shall not be unreasonably withheld, conditioned or delayed. Grantee hereby indemnifies, defends and holds Grantor and Grantor's successors and assigns harmless from and against and with respect to any and all Claims (hereafter defined) asserted against Grantor and/or Grantor's successors and assigns with respect to Grantee's Environmental Obligations and those obligations of Grantee set forth in this Section 7, except for those Claims that may arise out of: (i) Grantor's gross negligence or willful misconduct, or (ii) Existing Contamination Conditions (hereafter defined), as more particularly described in Section 8(b) below.

(b) Notwithstanding anything contained in this License to the contrary, Grantor does hereby assume and retain responsibility for and does hereby release Grantee and Grantee's successors and assigns, from, against and with respect to any and all actions, causes of action, complaints, claims, costs, damages, liabilities and losses (collectively, "Claims"), which Grantor and/or Grantor's successors and assigns, or anyone claiming through or under Grantor and/or Grantor's successors and assigns, may hereafter have against Grantee and/or Grantee's successors and assigns with respect to the presence of Hazardous Substances (as defined in this Section 7) existing on, at, under or originating from the Temporary Construction License Area (including soils, groundwater or any other media) as of the date of this License, except to the extent such conditions are caused by Grantee prior to date of this License (the "Existing Contamination Conditions") and Grantor further indemnifies, defends and holds Grantee and Grantee's successors and assigns harmless from and against and with respect to any and all Claims asserted by third parties against Grantee and/or Grantee's successors and assigns with respect to the Existing Contamination Conditions; provided, however, that Grantor does not release Grantee and Grantee's successors and assigns from, nor does Grantor agree to indemnify, defend or hold Grantee and Grantee's successors and assigns harmless from or with respect to Grantee's Environmental Obligations.

(c) As used in this Section 7, the term "Hazardous Substances" shall mean any toxic or hazardous substance, material or waste or any pollutant or contaminant or infectious or radiologically contaminated or enhanced material, including, but not limited to, those substances, chemicals, wastes, toxicants, pollutants, pesticides, fungicides or contaminants regulated by any Environmental Law (as defined herein), including, without limitation, any petroleum products or fractions thereof.

(d) As used in this Section 7, the term "Environmental Law" shall mean any one or all local, state, and federal laws, rules, statutes, ordinances and regulations, now in effect or hereinafter enacted, that regulate or protect health and the environment, and shall include without limitation, any law, rule, statute, ordinance, regulation, judicial or administrative order, or consent decree which governs or addresses the quality, management or use of any air, ground water, surface water, soil, land, or any subsurface or sub-strata land, or the generation, treatment, storage, disposal, use or disposition of any

Hazardous Substance including, without limitation, the New Jersey Industrial Site Recovery Act, N.J.S.A. 13:1K-6 et seq., the New Jersey Spill Compensation and Control Act, N.J.S.A. 58:10-23.11, et seq., the New Jersey Brownfield and Contaminated Site Remediation Act, N.J.S.A. 58:10B-1 et seq., the New Jersey Site Remediation Reform Act, N.J.S.A. 58:10C-1 et seq., the NJDEP Technical Requirements for Site Remediation rules, at N.J.A.C. 7:26E-1, et seq., the NJDEP Administrative Requirements for the Remediation of Contaminated Sites, N.J.A.C. 7:26C-1, et seq. (the “ARRCS Rules”), and any amendments of such laws, regulations and codes and any successor thereto, as amended.

(e) The provisions of this Section 8 shall survive the expiration or termination of this License.

8. **Binding Effect.** By acceptance of this instrument, Grantor and Grantee agree to abide by the terms and conditions herein, and the provisions of this instrument shall inure to the benefit of and be binding upon the respective Parties hereto and their heirs, executors, administrators, successors, and assigns. The rights granted hereunder may not be assigned and transferred by Grantee, without the prior written consent of Grantor, which shall be in Grantor’s sole discretion.

9. **Severability.** If any of the provisions of this instrument shall be deemed invalid or unenforceable, such invalidity or unenforceability shall not invalidate or render unenforceable the entire instrument, but rather the entire instrument shall be construed as if not containing the particular invalid or unenforceable provision or provisions, and the rights and obligations of Grantor and Grantee shall be construed and enforced accordingly. Grantor assumes no responsibility or liability for any condition which may be disclosed by the entry onto the lands and interests being conveyed herein.

10. **Counterparts.** This instrument may be executed in one or more counterparts, together which shall constitute the same instrument.

11. **Insurance.** Grantee shall maintain in full force and effect Comprehensive General Liability (including Contractual Liability covering this agreement), Automobile Liability and Employer Liability insurance with minimum limits of \$1,000,000 per occurrence for both bodily injury and property damage. Workmen’s Compensation coverage shall be the minimum statutory limits required by law. Grantor shall maintain in full force and effect property owner’s insurance covering the Property, which shall contain comprehensive general liability coverage. In addition,

Grantee shall require that its contractors performing the work in the Temporary Construction License Area maintain the same insurance requirements, naming the Grantor as an additional insured on the policies. On request, each party shall provide evidence of each policy of insurance obtained or maintained as required herein.

12. **Terms of License.**

(a) Grantee agrees that all work to be performed pursuant to the rights granted herein shall be performed in a safe, good and workmanlike manner, with due regard for the safety of persons and the property of Grantor and others, and in conformity with all applicable governmental statutes, ordinances, rules and regulations, permits and approvals.

(b) Grantee shall not impair, restrict or prevent free, ready and continuous passage by Grantor or its agents, invitees, licensees, successor and assigns, over the Temporary Construction License Area except on a temporary basis as reasonably necessary during construction or maintenance, and upon at least twenty-four (24) hours' prior written notice to Grantor, except that in the event of an emergency, notice shall be given as promptly as possible.

(c) Notwithstanding anything to the contrary herein, the rights provided for herein are subject to any and all existing rights of way, interests, conditions, leases, easements and restrictions currently in effect for the Temporary Construction License Area.

(d) No mechanic's or other lien for such labor or materials shall attach to or affect any estate or interest of Grantor in and to all or any portion of Grantor's Property. If any vendor's, mechanic's, laborer's or materialman's statutory or similar lien is filed or claimed against Grantor's property or any other property owned by Grantor by reason of work, labor, services or materials supplied or claimed to have been supplied to all or any portion of the Temporary Construction License Area by Grantee, Grantee shall promptly after notice of such filing or claim, cause the same to be discharged of record or bonded.

13. **NO GUARANTY/WARRANTY.** The parties acknowledge and agree that the Borough is making no guaranty and not providing any warranty that the work being performed will address all the issues that may exist relating to the stream on the Property, including, without limitation, that such work will ultimately solve any stormwater issues or not cause any future issues or damages to the Property. The Parties further acknowledge and agree that the Borough's

performance of such work herein authorized is being done to address any future public concerns; and is not assuming any ongoing maintenance, repair, nor any easement or other property interest in the Property or the improvements being provided thereon. The Property remains private property; and any and all future maintenance, repair or other work required on the Property shall remain the responsibility of the Grantor.

14. **Self Help.** If a party fails to perform, fulfill or observe any agreement contained within this License on its part to be performed, fulfilled or observed, that continues for thirty (30) days after written notice, or if an emergency exists that threatens damage to persons or property, or any portion or any part thereof, the other party, at its election, may cure such failure or breach on behalf of the breaching party. Any amount that is expended to remedy any breach shall be reimbursed by the breaching party to the other party within ten (10) business days after presentation of an invoice for such services.

[Signature page follows.]

IN WITNESS WHEREOF, by execution of this License, Grantor has accepted the terms of this Temporary Construction License the day and year first above written.

WITNESS:

Name:

Dated: _____, 2024

GRANTOR:

Gerhard Liepold

WITNESS:

Name:

Dated: _____, 2024

Sigrid Liepold

WITNESS:

Edith Gil, Borough Clerk

Dated: _____, 2024

GRANTEE:

Ronald Jubin, Mayor

**BOROUGH OF WATCHUNG
ORDINANCE 24/14**

**ORDINANCE REVISING CHAPTER 2, ADMINISTRATION, OF THE
CODE OF THE BOROUGH OF WATCHUNG TO ESTABLISH THE
WATCHUNG YOUTH SERVICES COMMISSION**

WHEREAS, the Borough of Watchung has previously established The Watchung Borough Youth Services Commission by Resolution adopted December 18, 2003, pursuant to N.J.S.A. 9:22-1, to assist in determining the needs of the community and provide a vision to coordinate activities of the Borough's youth; and

WHEREAS, the Commission also serves as a conduit between the Borough and the County of Somerset with regard to the receipt of grants for recreational and school activities; and

WHEREAS, the Mayor and Borough Council now desire to establish the Commission more formally by Ordinance and codify same in the Borough Code.

NOW, THEREFORE, BE IT ORDAINED by the Mayor and Borough Council of the Borough of Watchung, in the County of Somerset and State of New Jersey as follows:

Section 1. Section 2-48 entitled "(Reserved)" of Article V entitled "Boards, Committees, and Commissions" of Chapter 2 entitled "Administration" of The Code of the Borough of Watchung is hereby supplemented and amended to establish and codify the Borough's youth services commission to read as follows:

Chapter 2. Administration.

Article V. Boards, Committees, and Commissions

§2-48. ~~(Reserved)~~ Watchung Borough Youth Services Commission

§2-48.1. Purpose; Established.

A. Pursuant to the authority granted to local municipalities by resolution of the County of Somerset, State of New Jersey, and consistent with N.J.S.A. 52:17B-169, *et seq.*, and N.J.A.C. 13:90-2.1, *et seq.*, the Borough of Watchung hereby establishes a Youth Services Commission to be known as “The Watchung Borough Youth Services Commission.”

B. Purpose and responsibilities.

1. It shall be the purpose of the Watchung Borough Youth Services Commission to encourage, coordinate and integrate existing services for youth at risk of or already involved in the juvenile justice system by determining the needs of at-risk youth in their community, developing and proposing new innovative programs to meet the identified needs and informing the public of the availability of service to meet those needs.
2. The Commission shall work collaboratively with the Somerset County Youth Services Commission in their responsibility of assessing the needs of youth within the Borough of Watchung in order to develop appropriate prevention and intervention strategies that address those issues.
3. In carrying out this purpose, the Commission shall fulfill the following responsibilities:
 - (a) Provide an open forum to foster communication, education and information concerning problems and opportunities that exist within the community for youth;
 - (b) Assess the needs of the community’s youth;
 - (c) Advise on and recommend planning, policy and programs for the community’s youth;
 - (d) Explore various resources to meet the local community needs; and
 - (e) Assist in the development of a plan of action to implement recommended programs to the Borough.

C. Guiding principles of the Commission should include:

- Valuing youth
- Empowering youth
- Strengthening families
- Promoting healthy alternatives
- Supporting diversity
- Encouraging community based services
- Networking
- Youth / Adult Partnerships

- Access to services
- Community based youth development programs

§2-48.2. Appointments; Membership; and Qualifications.

- A. The Youth Services Commission shall consist of a minimum of seven (7) members, with a maximum of fifteen (15) members. The Commission shall consist of, but not limited to:
1. A member of the Watchung Borough Council;
 2. A representative of the Watchung Borough School District;
 3. A representative of the Recreation Committee;
 4. A Police Officer;
 5. A member of the Parent-Teacher Organization (PTO);
 6. Other members-at-large who are residents and/or employees of the Borough of Watchung and the Watchung Borough School District having an interest in youth.
- B. All members of the Commission shall be appointed by the Mayor, with the advice and consent of the Borough Council. Each member shall be chosen with consideration to their qualifications and fitness for service with regard to the purposes and responsibilities of the Commission as defined in this Section. In order to achieve the goals of the Commission, the direct involvement of a cross-section of local government, education, law enforcement and community leaders who live and/or work in the Borough is of preference.
- C. Members of the Commission shall be appointed to serve for a term of three (3) years or until their successors be appointed, with the exception that the terms of a member of the Borough Council and School District shall be annual and consistent with their respective terms of office. All terms shall begin as of January 1 of the year of their appointment and expire on December 31 of the last year of their term. Initially appointments to the Commission shall be staggered so that no more than 3 members are to be appointed/reappointed in any year, with the exception of the members of the Borough Council and School District.
- D. The Officers of the Commission shall consist of a Chairperson, Vice-Chairperson, Secretary and Treasurer, who shall be elected by the general membership at the annual reorganization meeting, and shall serve for a period of one (1) year.
1. Chairperson. This member shall preside at all meetings, prepare the meeting agenda, appoint special committees to address specific issues and serve as an ex-officio member of all committees.
 2. Vice-Chairperson. This member shall, in the absence of the Chairperson, assume the responsibilities of the Chairperson.
 3. Secretary. This member shall take minutes of the proceedings at all meetings, sent the minutes to the membership, and send the approved minutes to the Borough

Clerk for acknowledgment and acceptance by the Borough Council. This member shall also provide for adequate notice of all meetings in accordance with the Open Public Meetings Act.

4. Treasurer. This member shall periodically file with the Borough Council a report giving a complete account of all financial transactions and a statement of activities showing the expenditure of public funds and the receipts, expenditure of fees, and charges collected. A separate budget account shall be maintained to record money and tangible personal property donated for current use. The Treasurer shall keep adequate records of all funds for long term projects handled by the Commission. The Commission shall approve all vouchers for the expenditure of funds of any character. The Treasurer shall report on the status of the funds at each meeting. In lieu of the need for a Treasurer, the Borough Chief Financial Officer will assume these duties.
- E. Vacancy. Any vacancy occurring other than by expiration of the term shall be filled for the unexpired term in the same manner as the original appointment for such member.
- F. All members and officers of the Youth Services Commission shall serve without compensation.

§2-48.3. Powers and Duties.

- A. The Youth Services Commission shall perform the following functions and duties:
 1. Provide an open forum to foster communication, education and information concerning problems and opportunities that exist within the community for youth;
 2. Advise on and recommend the planning and development of programs for youth;
 3. Serve as the functioning body in the development of plans in the areas of youth services;
 4. Assess the needs of the community's youth throughout the calendar year;
 5. Identify service gaps and priorities;
 6. Explore various means and resources to meet the local community needs;
 7. Assist in the development of a plan of action to implement recommended programs;
 8. Advise the Mayor, Borough Council, and administration on the availability of grant programs and economic initiatives relating to youth services;

9. Make recommendations to the Mayor and Borough Council with regard to any purchase or contract for the promotion of youth services within the Borough, with the final decision whether to enter or award such purchase or contract being at the sole discretion of the governing body;
 10. Carry out other related duties as may be assigned from time to time by the Borough Council; and
 11. Prepare and provide an annual report to the Mayor and Borough Council during December of each year setting forth, in detail, its operations and recommendations covering the preceding twelve (12) months.
- B. The Youth Services Commission shall coordinate its efforts with the Somerset County Youth Services Commission and shall be guided by the rules and regulations adopted thereby, including but not limited to the procurement of grants consistent with this Section and in furtherance of the purpose and mission of the Commission.
- C. By-laws; Subcommittees.
1. The Youth Services Commission shall adopt and establish By-laws to govern the Commission, within the parameters and authorities granted in this Section. The By-laws shall be reviewed and updated, if necessary, on an annual basis, and shall be subject to approval by the Borough Council. At a minimum, the By-laws shall include the following (consistent with the terms of this Section):
 - a. Name of Commission
 - b. Purpose and Function
 - c. Objectives
 - d. Organization, including Commission descriptions
 - e. Membership and Terms of Office
 - f. Officers
 - g. Duties of Officers
 - h. Nomination and Election of Officers
 - i. Meetings (Conduct, Cancellation or Addition of Meetings)
 - j. Other considerations of Members.
 2. The Youth Services Commission shall have the power to establish standing and ad hoc subcommittees as needed, including, but not limited to, an adjustment subcommittee consisting of persons qualified by experience and training to assist in and coordinate the efforts of police, school and other agencies to provide guidance and counsel to youth with incipient behavior and to cooperate with the Superior Court, Chancery Division, Family Part, having jurisdiction when cases arise in which official adjudication of delinquency seems indicated.
- D. Budget; Funding; Expenditures.

1. The Youth Services Commission shall have a budget as authorized by the Borough Council.
2. The Youth Services Commission is authorized to submit applications for grant funding, subject to the approval of the Borough Council.
3. On a periodic basis, but at least quarterly, the Youth Services Commission shall submit a detailed accounting of all anticipated expenditures to the Borough Council for review and approval. Goods and services cannot be procured by the Commission without approval from the Borough Council.
4. The Youth Services Commission shall not have any powers or authorities other than those set forth herein. Specifically, the Commission shall not have the power or authority to expend public funds outside of its budget, pledge the credit of the Borough or otherwise incur indebtedness, or enter into contracts on behalf of itself or the Borough, without the approval of the Borough Council.

§2-48.4. Meetings.

- A. Meetings of the Youth Services Commission shall comply with the requirements of Open Public Meetings Act, N.J.S.A. 40:4-6, *et seq.*; and shall follow the Roberts Rules of Order.
- B. The Youth Services Commission shall hold a re-organization meeting each calendar year, to be held on or before January 10th of each year, at which time the Commission shall establish its regularly scheduled meeting dates, and elect its officers. The Commission shall schedule a minimum of six (6) meetings in a calendar year.
- C. The Youth Services Commission shall keep accurate minutes of its meetings and activities; and approved minutes shall be filed with the Borough Clerk.
- D. A majority of the current appointed members of the Commission shall constitute a quorum for the holding of a meeting of the Commission.
- E. All decisions of the Commission shall be decided by a simple majority vote of those present at a meeting

BE IT FURTHER ORDAINED by the Council of the Borough of Watchung that should any section, paragraph, sentence, clause, or phrase of this Ordinance be declared unconstitutional or invalid for any reason, the remaining portions of this Ordinance shall not be affected thereby and shall remain in full force and effect, and to that end the provisions of this Ordinance are hereby declared to be severable; and

BE IT FURTHER ORDAINED by the Council of the Borough of Watchung that in the event of any inconsistencies between the provisions of this Ordinance and any prior ordinance of the Borough of Watchung, the provisions hereof shall be determined to govern, and the inconsistencies of the prior ordinance are hereby repealed. All other parts, portions and provisions of the Ordinances of the Borough of Watchung are hereby ratified and confirmed, except where inconsistent with the terms hereof; and

BE IT FURTHER ORDAINED by the County of the Borough of Watchung that within five (5) days after its adoption by the Council, this Ordinance shall be presented to the Mayor for his approval and signature, which approval shall be granted or denied within ten (10) days of receipt of same, pursuant to N.J.S.A. 40A:60-5(d). If the Mayor fails to return this Ordinance with either his approval or objection to same within ten (10) days after it has been presented to him, then this Ordinance shall be deemed approved; and

BE IT FURTHER ORDAINED by the Council of the Borough of Watchung that this Ordinance shall take effect upon final passage and publication according to law; and approval by the Mayor pursuant to N.J.S.A. 40A:60-5(d).

INTRODUCED BY: GIBBS
PASSED:
PUBLISHED:
ADOPTED:
CC:

ATTEST:

BOROUGH OF WATCHUNG

Edith Gil, Borough Clerk

By: _____
Ronald Jubin, Mayor

**BOROUGH OF WATCHUNG
RESOLUTION: R11**

WHEREAS, Section 8 of the Open Public Meetings Act (N.J.S.A. 10:4-12(b)(1-9) permits the exclusion of the public from a meeting in certain circumstances; and

WHEREAS, the Governing Body is of the opinion that such circumstances presently exist.

NOW, THEREFORE, BE IT RESOLVED by the Council of the Borough of Watchung, County of Somerset, State of New Jersey, as follows:

1. The public shall be excluded from discussion of the closed session of August 15, 2024.
2. The general nature of the subject matter to be discussed:
 - a. Contract negotiations regarding Bonnie Burn PILOT Agreement
 - b. Contract negotiations regarding Bonnie Burn Sewer & Easement Agreements
 - c. Anticipated Litigation on various properties (Cedar Road, Tuttle Road, Upper Drive)
 - d. Anticipated Litigation: Affordable Housing Litigation
3. Minutes will be kept and once the matter involving the confidentiality of the above no longer requires that confidentiality, then the minutes can be made public.
4. The Borough Council may take official action on those items discussed in executive session upon completion of the executive session.

Christine B. Ead, Council President

Ronald Jubin, Ph.D., Mayor

ADOPTED: AUGUST 15, 2024
INDEX: MISC.
C: